

70289

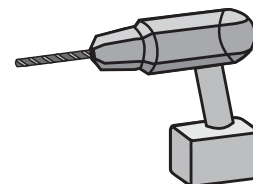
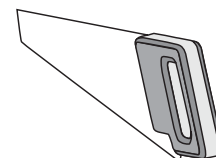
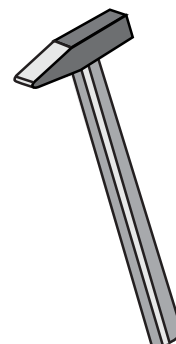
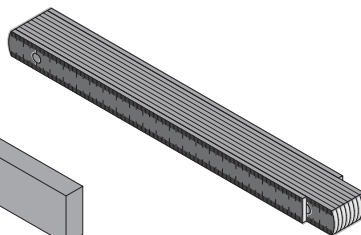
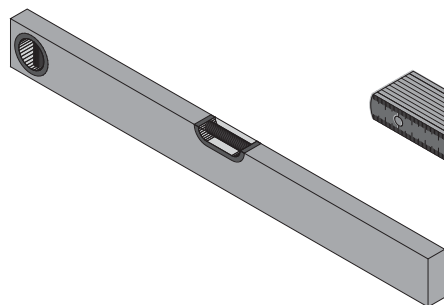
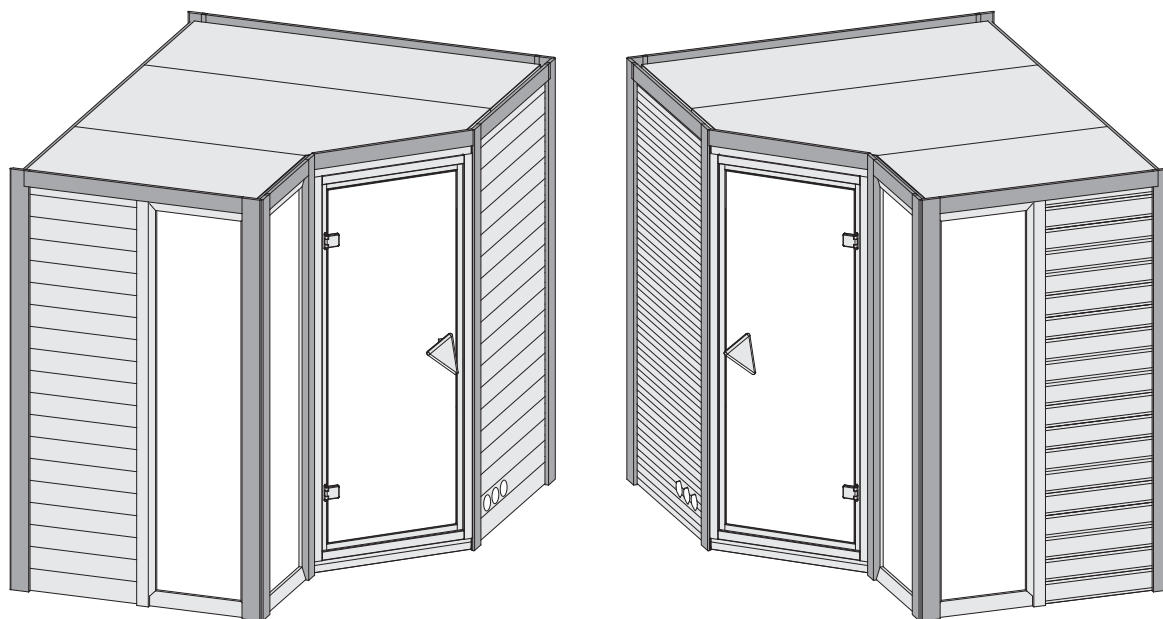

 **Aufbauanleitung**

 **notice de montage**

 **Building Instructions**

 **montagehandleiding**

 **Instrucciones de construcción**

 **Istruzioni per il montaggio**

 **Montážní návod**

 **Service-Hotline: +49 421 38693 33**



Vergleichen Sie zuerst die Materialliste mit Ihrem Paketinhalt! Bitte haben Sie Verständnis, dass Beanstandungen nur im nicht aufgebauten Zustand bearbeitet werden können!



En primer lugar, compare la lista de material con el contenido del paquete. Rogamos entienda que las reclamaciones sólo pueden ser tramitadas antes de montar el objeto!



Nejprve přezkontrolujte obsah balení podle materiálového listu! Mějte pochopení pro to, že případnou reklamaci se můžeme zabývat pouze tehdy, když díly nebudou smontované! Za pomoci tohoto seznamu můžete jednotlivé díly přiřadit k montážnímu návodu.



Vergelijk eerst de lijst van materialen met de inhoud van uw pakket! Reclamaties kunnen alleen in behandeling worden genomen zolang de onderdelen nog niet zijn gemonteerd!



First compare the list of materials with your package contents! Please understand that complaints can be processed in the non-built status only!



Commencez par comparer la liste du matériel avec le contenu de votre paquet! Sachez que nous traitons uniquement les réclamations concernant le matériel à l'état non monté!



Confrontate questa distinta materiali prima con il contenuto del pacchetto! Vi preghiamo di comprendere che eventuali reclami possono essere accolti solo prima del montaggio!

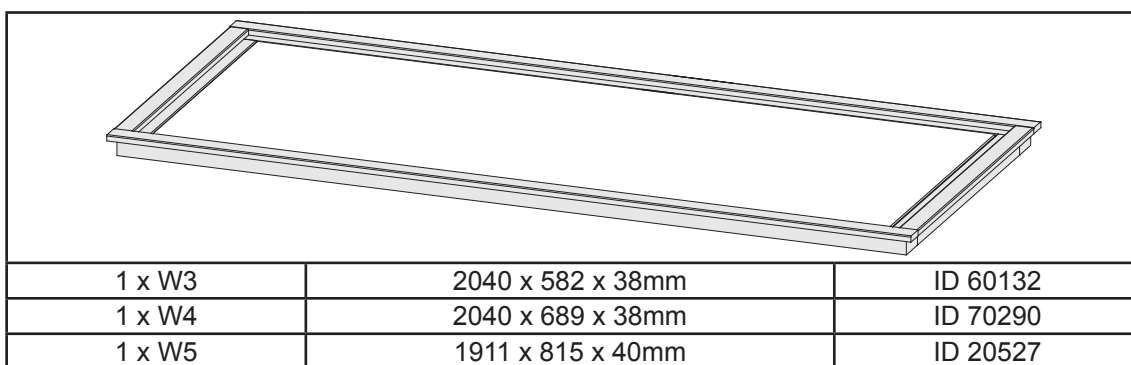
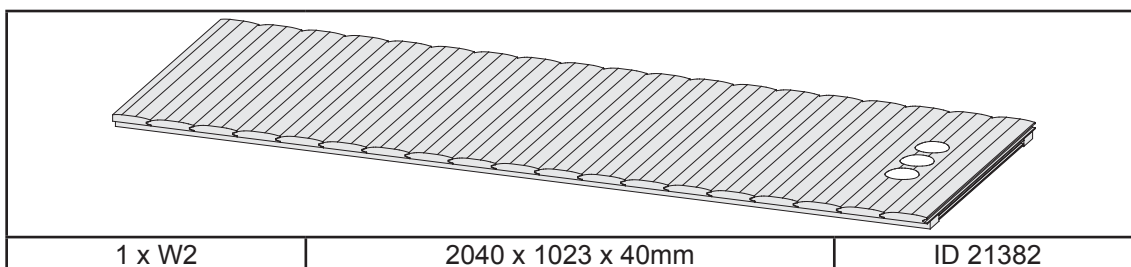
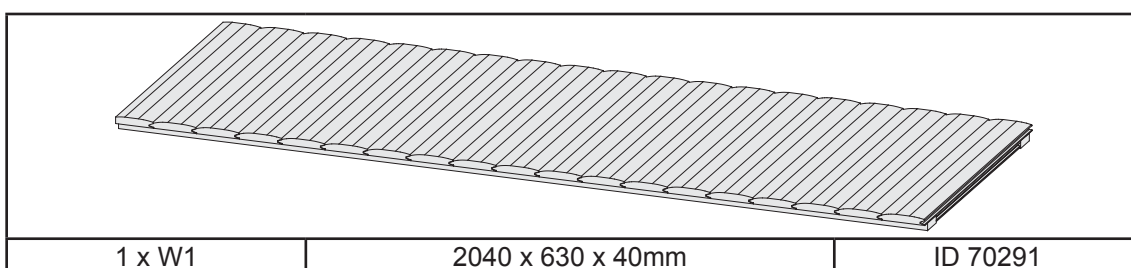
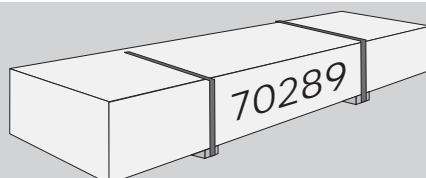

1 x W6

2040 x 2324 x 40mm

ID 20820

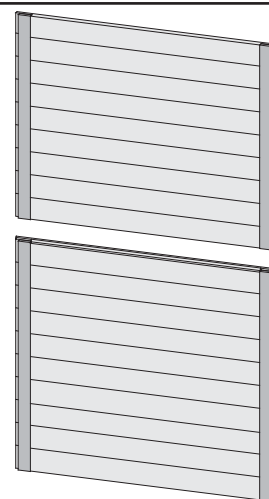

1 x W7

2040 x 1770 x 40mm

ID 20719

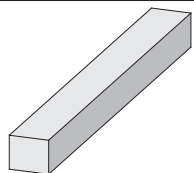

1 x B1	600 x 78 x 17mm	ID 48532
1 x B2	900 x 78 x 17mm	ID 48531
1 x B3	1000 x 78 x 17mm	ID 48528
1 x B4	1200 x 78 x 17mm	ID 48527
1 x B5	1800 x 78 x 17mm	ID 48524
2 x B6	800 x 45 x 18mm	ID 24796
1 x B7	1100 x 45 x 18mm	ID 21085
1 x B8	1675 x 45 x 18mm	ID 21086
1 x B9	2020 x 58 x 18mm	ID 23190
1 x B10	300 x 95 x 18mm	ID 19130
4 x B11	480 x 95 x 18mm	ID 20930
4 x B12	565 x 95 x 18mm	ID 15498
2 x B13	60 x 38 x 28mm	ID 20928
3 x B14	575 x 38 x 28mm	ID 21788
2 x B15	1120 x 38 x 28mm	ID 26146
1 x B16	1156 x 38 x 28mm	ID 20693
1 x B17	1731 x 38 x 28mm	ID 20698
1 x B18	2191 x 38 x 28mm	ID 20700
2 x B19	800 x 58 x 28mm	ID 41003

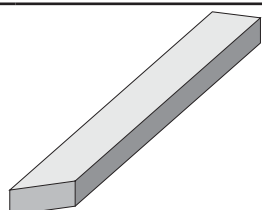

1 x C1	654 x 38 x 28mm	ID 20689
1 x C2	973 x 38 x 28mm	ID 21782

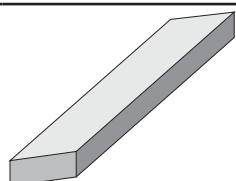

1 x C3	814 x 38 x 28mm	ID 20692
--------	-----------------	----------

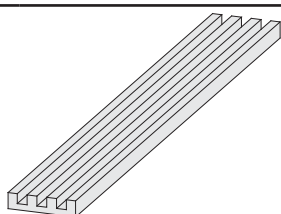

1 x E1	1850 x 140 x 26mm	ID 26480
--------	-------------------	----------

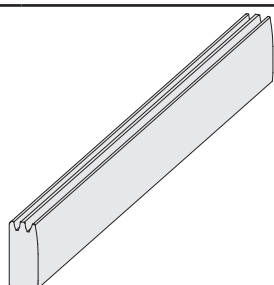

2 x E2	815 x 84 x 40mm	ID 20635
--------	-----------------	----------

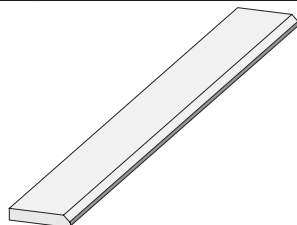

6 x E3	2085 x 78 x 17mm	ID 48525
2 x E4	2085 x 95 x 17mm	ID 48535

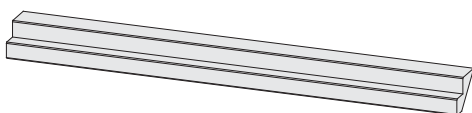

1 x E5	2040 x 61 x 38mm	ID 20702
--------	------------------	----------

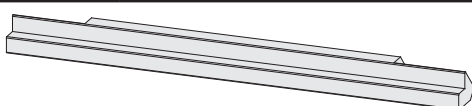

1 x E6	2040 x 61 x 38mm	ID 20701
--------	------------------	----------

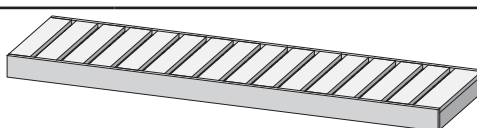

1 x L1	1177 x 500 x 90mm	ID 52065
2 x L2	2243 x 550 x 90mm	ID 52063

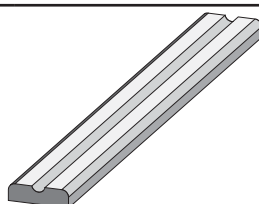

1 x L3	1177 x 90 x 22mm	ID 65701
1 x L4	1745 x 90 x 22mm	ID 26155
1 x L5	2243 x 90 x 22mm	ID 26119

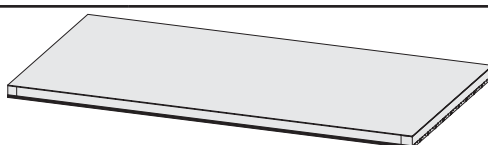

1 x M1	1152 x 681 x 57mm	ID 43922
1 x M2	1727 x 658 x 57mm	ID 43923

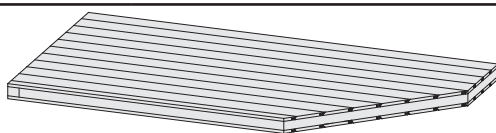

1 x M3	1727 x 904 x 68mm	ID 56972
--------	-------------------	----------

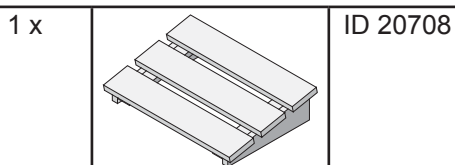

1 x		ID 20708
-----	--	----------

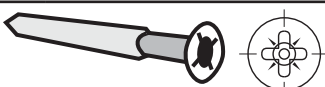

60 x	4,5 x 40mm	ID 26285
------	------------	----------



80 x	4 x 35mm	ID 3687
100 x	4 x 50mm	ID 3688
25 x	4 x 70mm	ID 3689
25 x	6 x 60mm	ID 14014
6 x	6 x 80mm	ID 47558



6 x S1		ID 14266
--------	--	----------



6 x S2	12 x 18mm	ID 46403
60 x S3	4,5 x 30mm	ID 26116

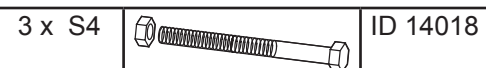

3 x S4		ID 14018
--------	--	----------

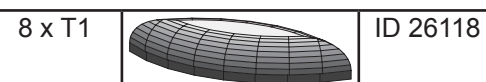

8 x T1		ID 26118
--------	--	----------



20 x		ID 14005
------	--	----------

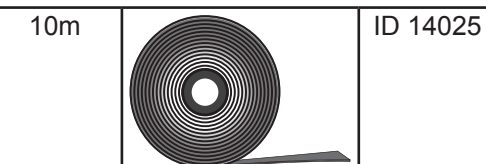

10m		ID 14025
-----	--	----------

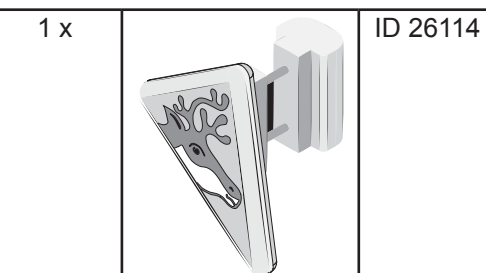

1 x		ID 26114
-----	--	----------

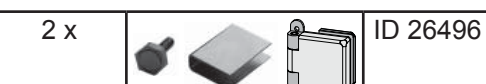

2 x		ID 26496
-----	--	----------

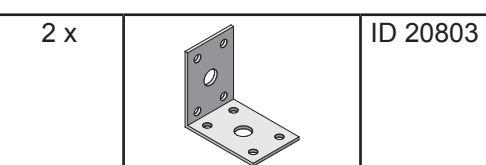

2 x		ID 20803
-----	--	----------

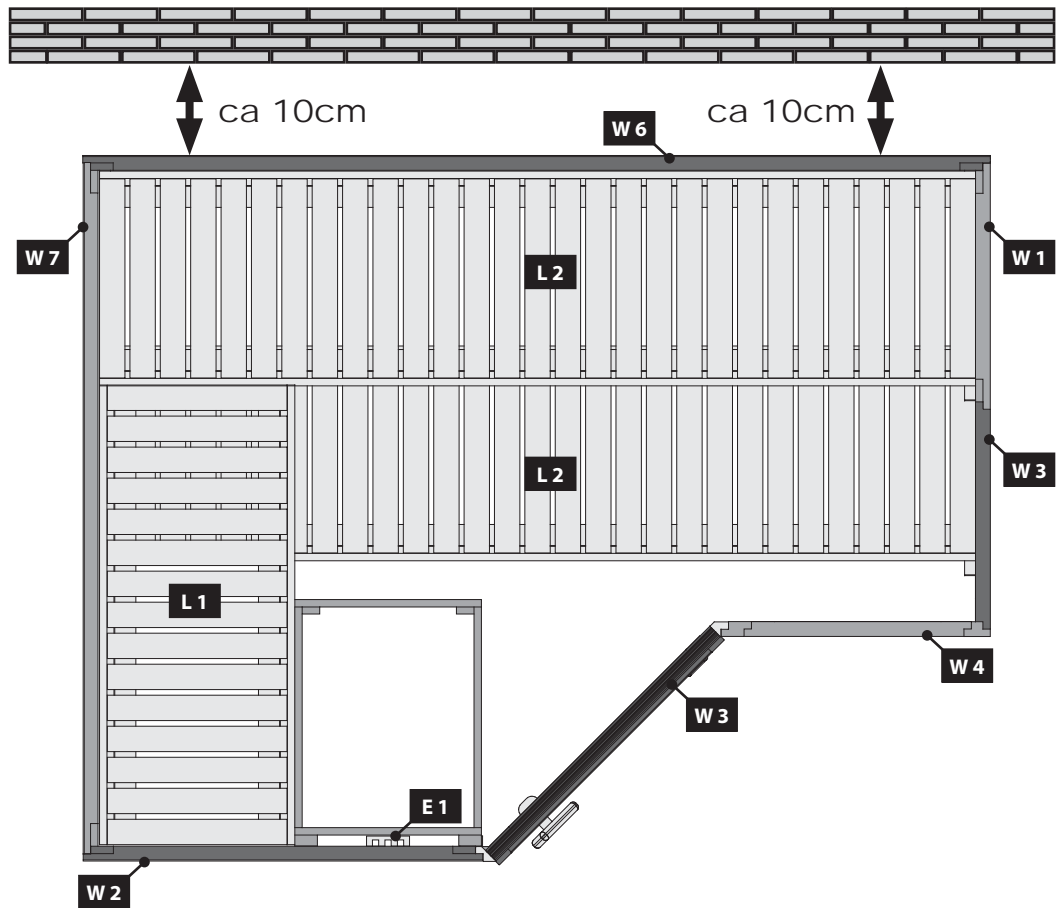
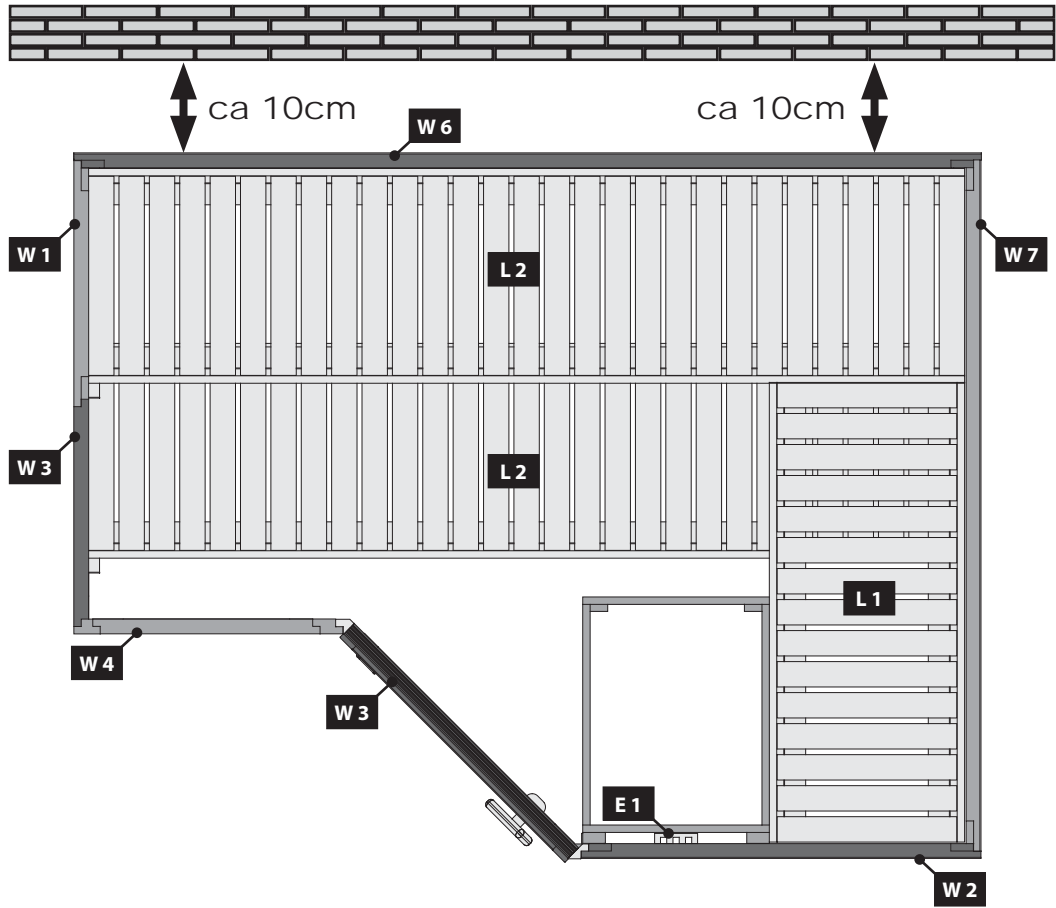

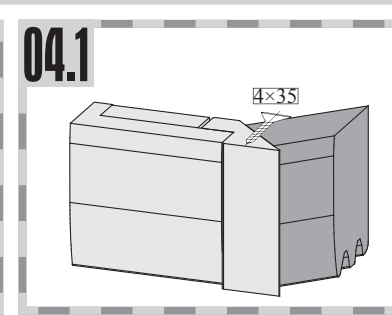
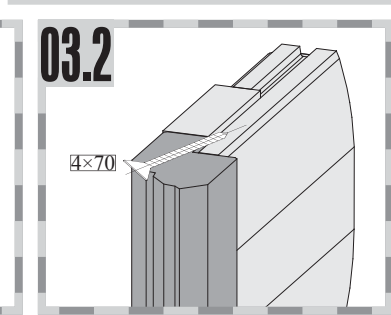
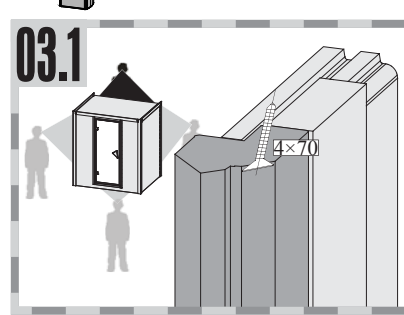
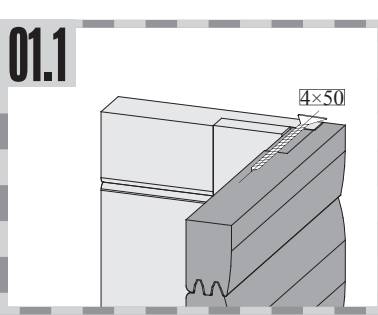
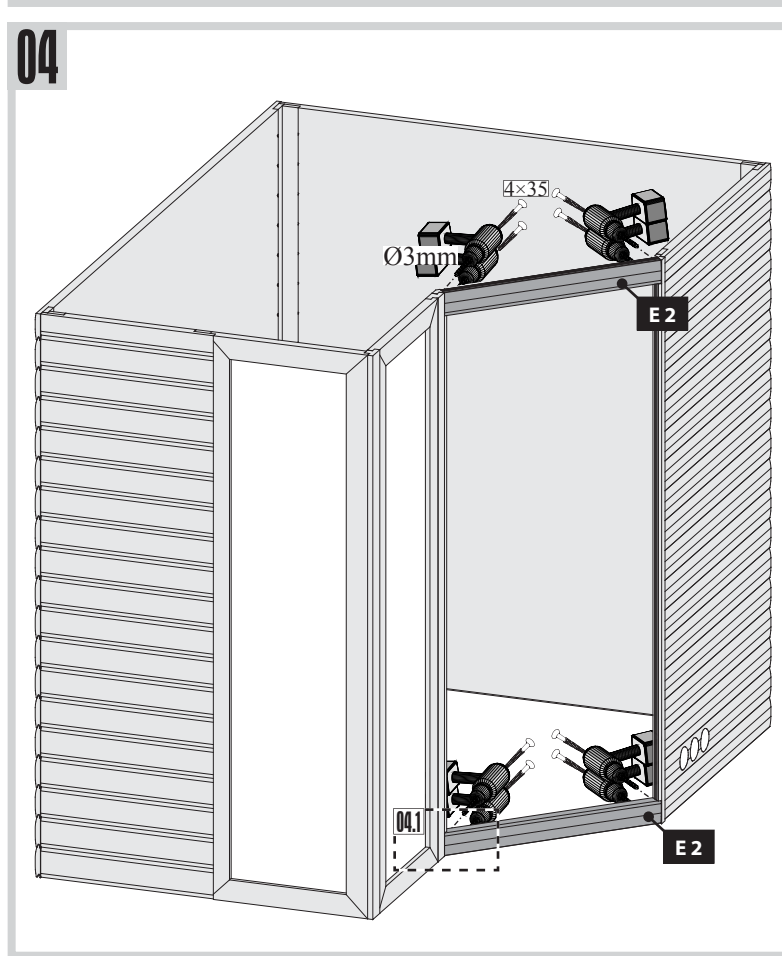
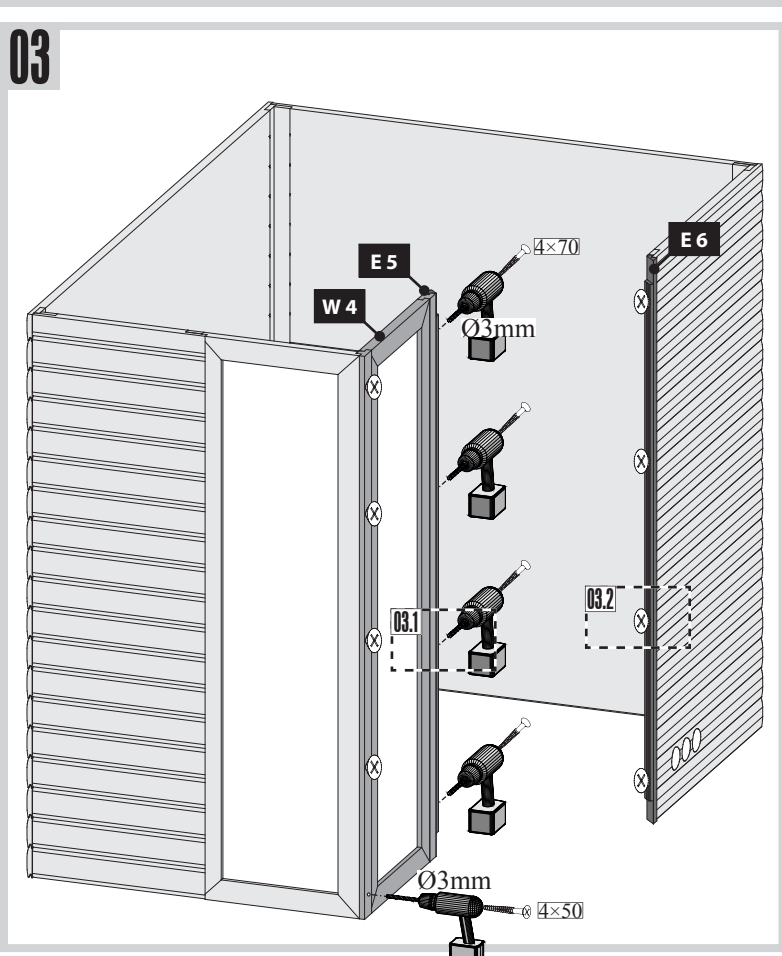
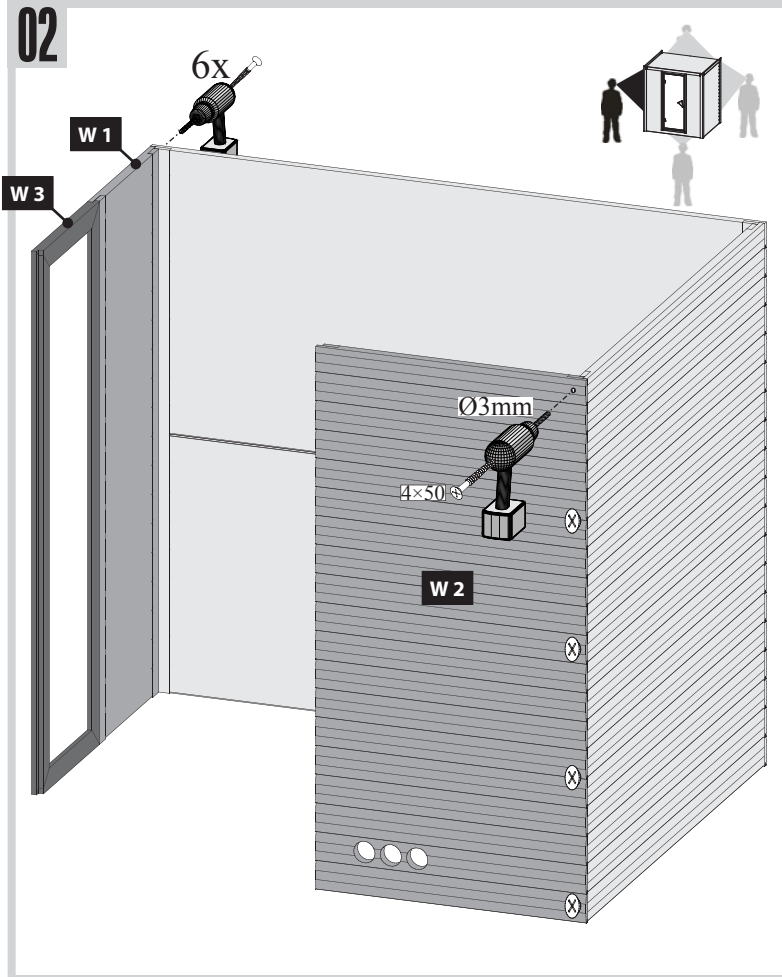
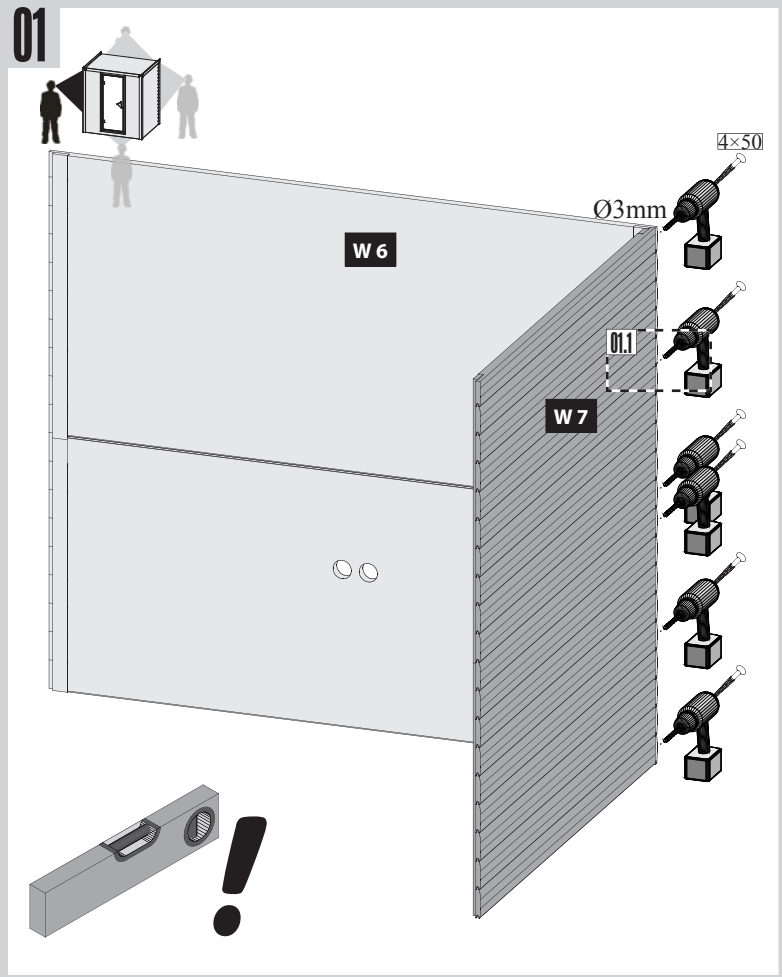

05

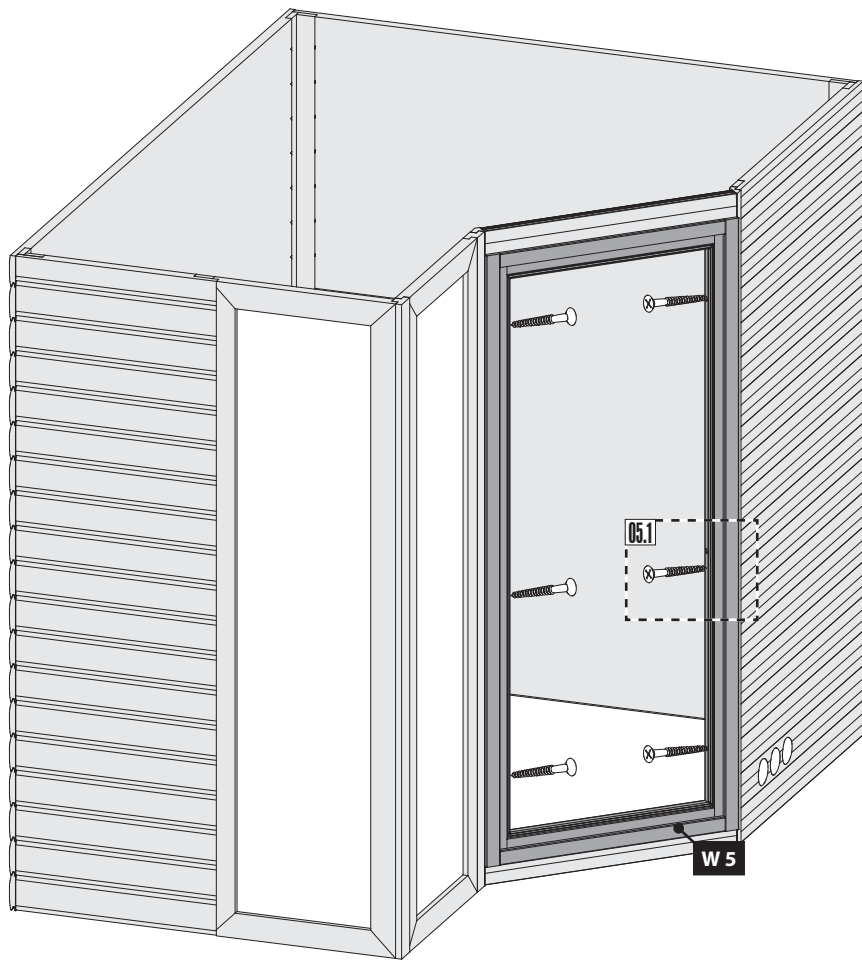



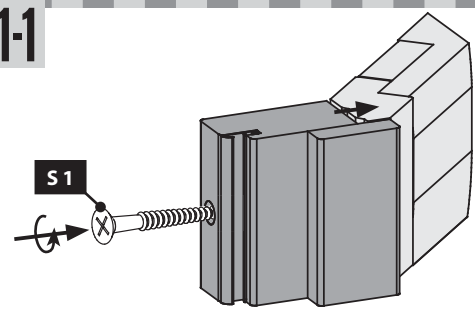

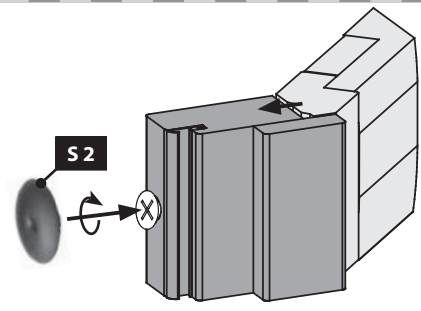

05.1-1



05.1-1



-  Einbau Glastür
-  Montage porte en verre
-  Installation of glass door
-  Montage van de glazen deur
-  Montaje de la puerta de cristal
-  Installazione portello di vetro

**!!! 01 — 03 !!!**

06

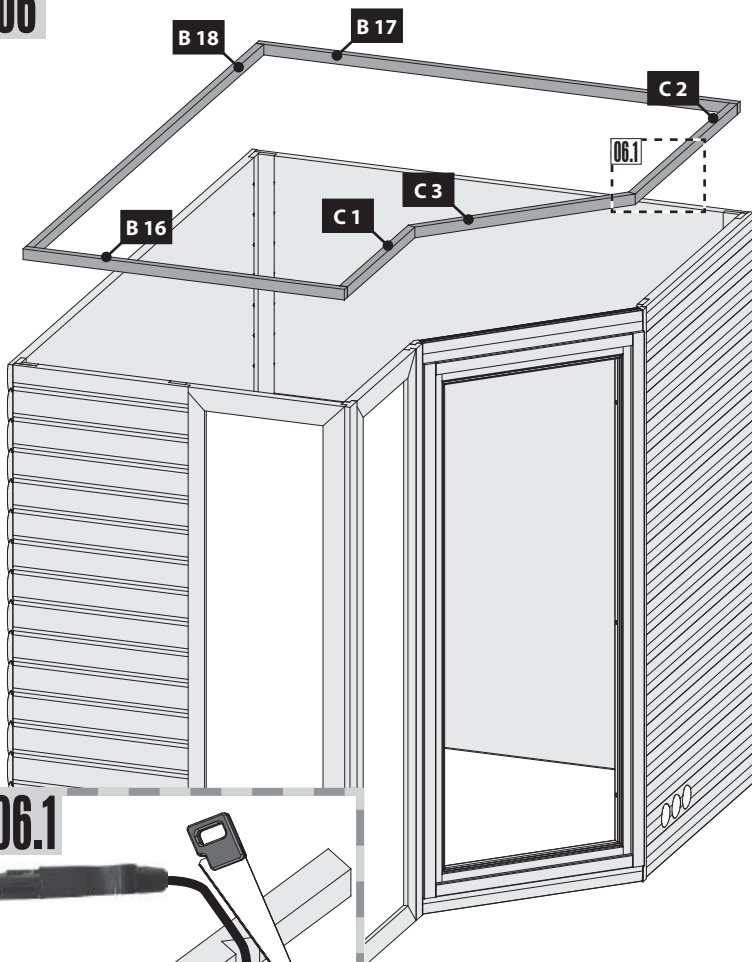

06.1

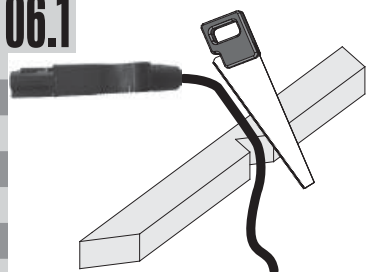

07

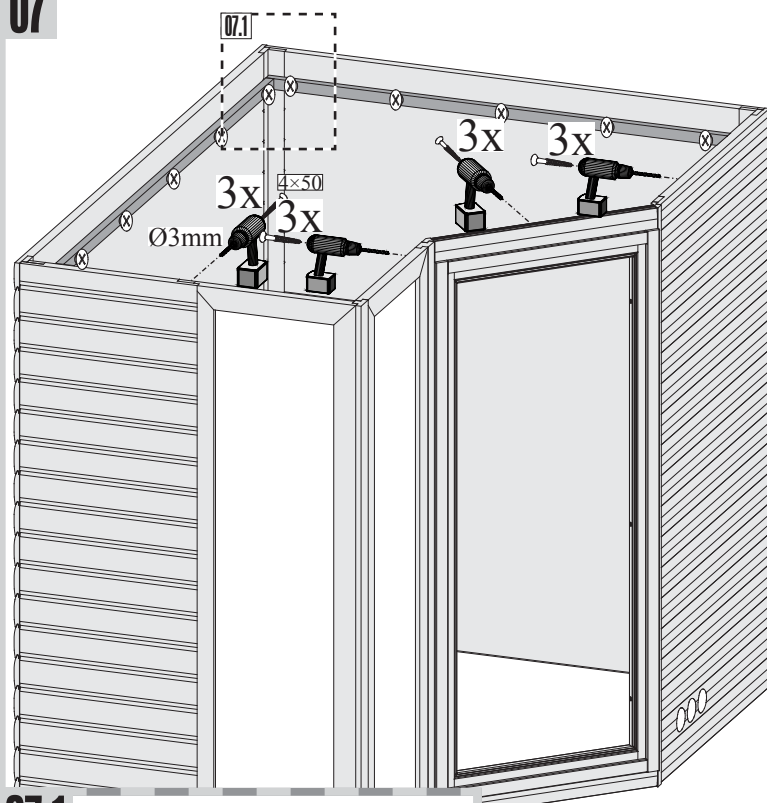

07.1

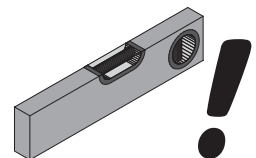
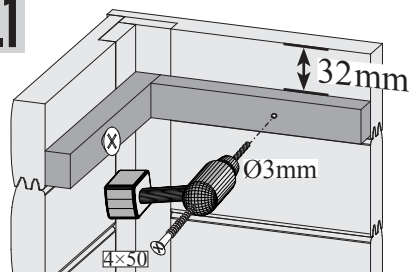

08

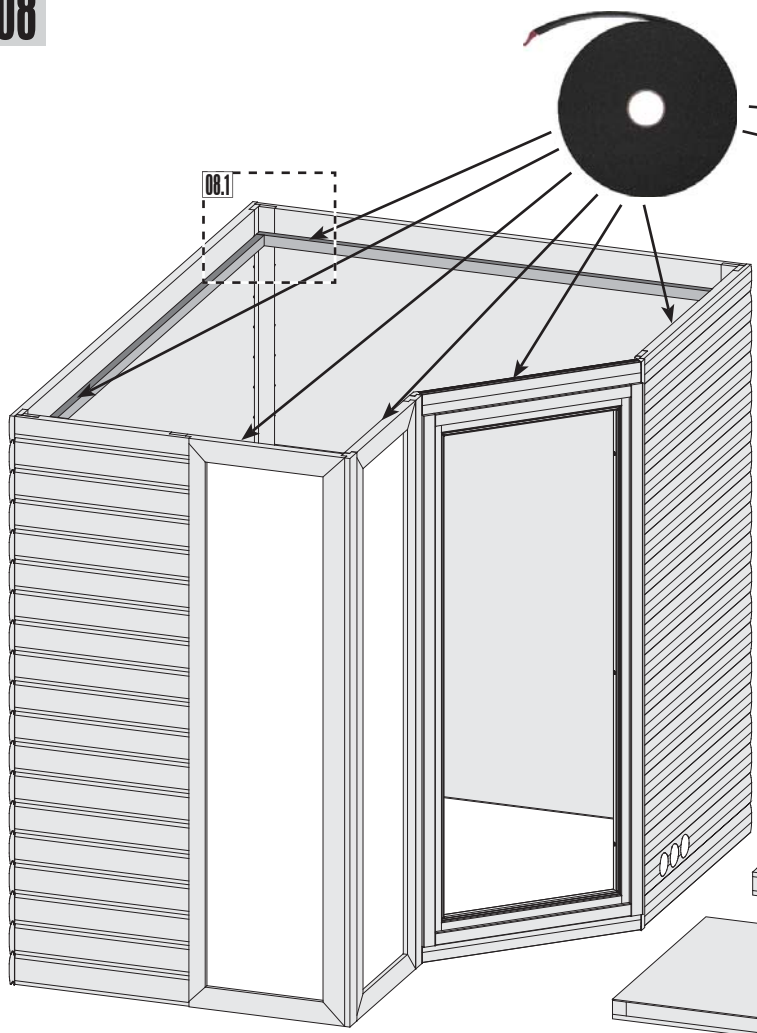

08.1

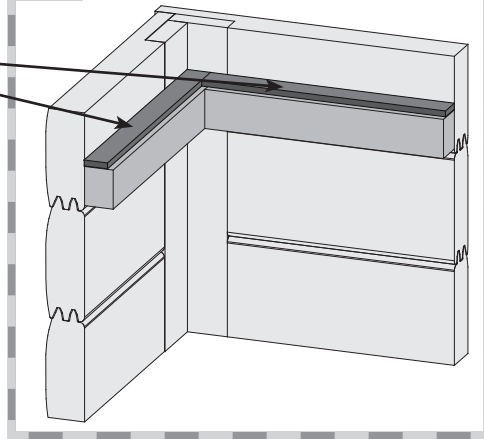

09

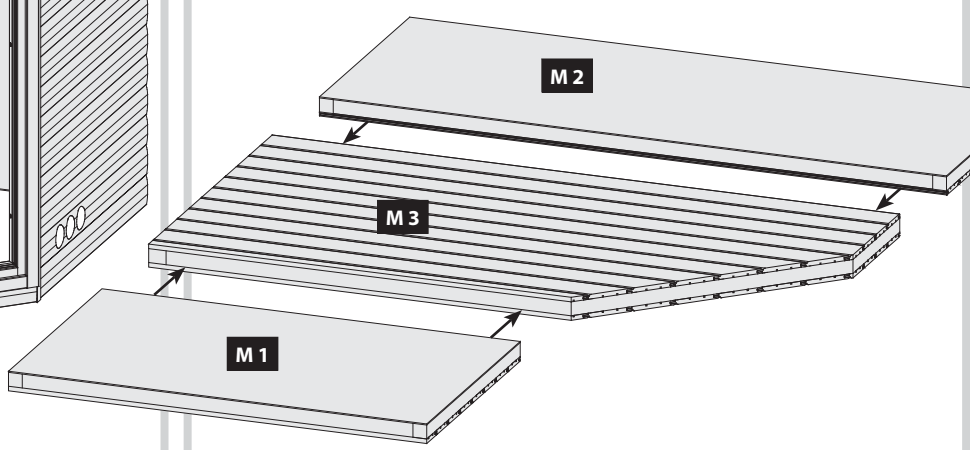

10

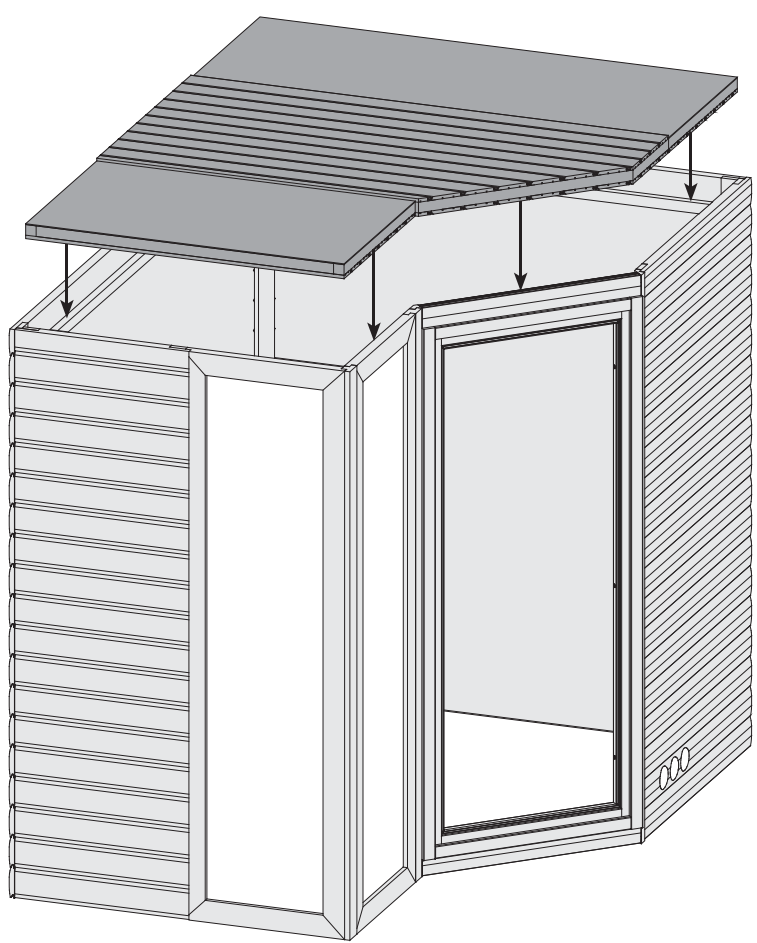

11

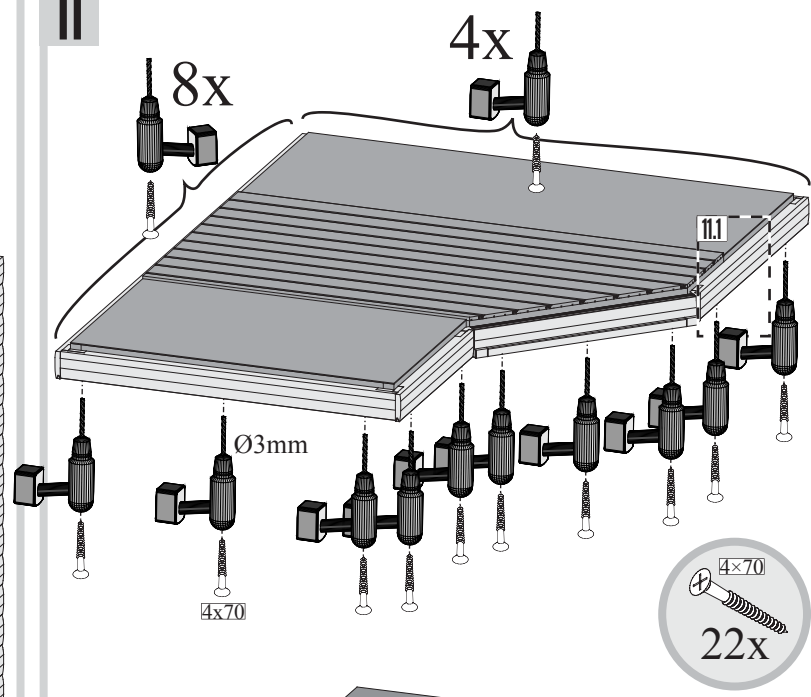

11.1

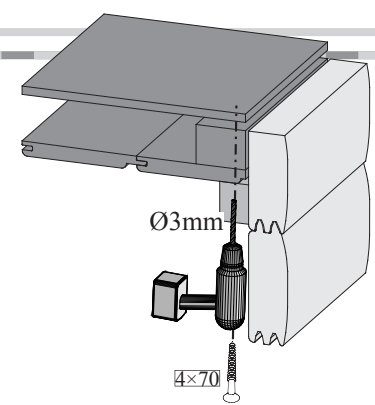

12

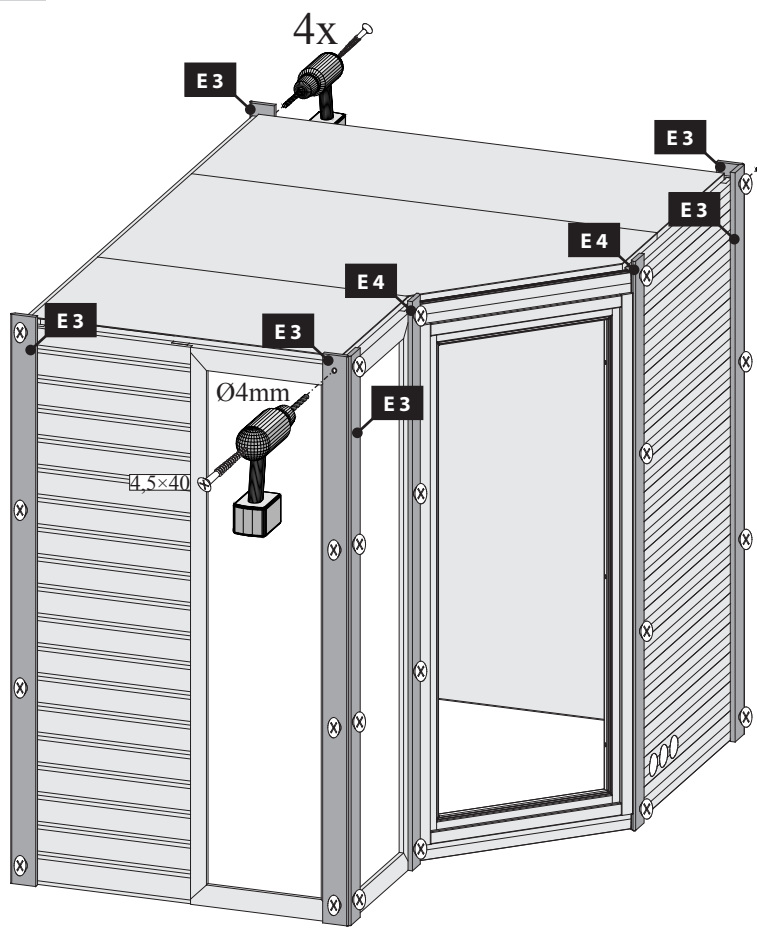

13

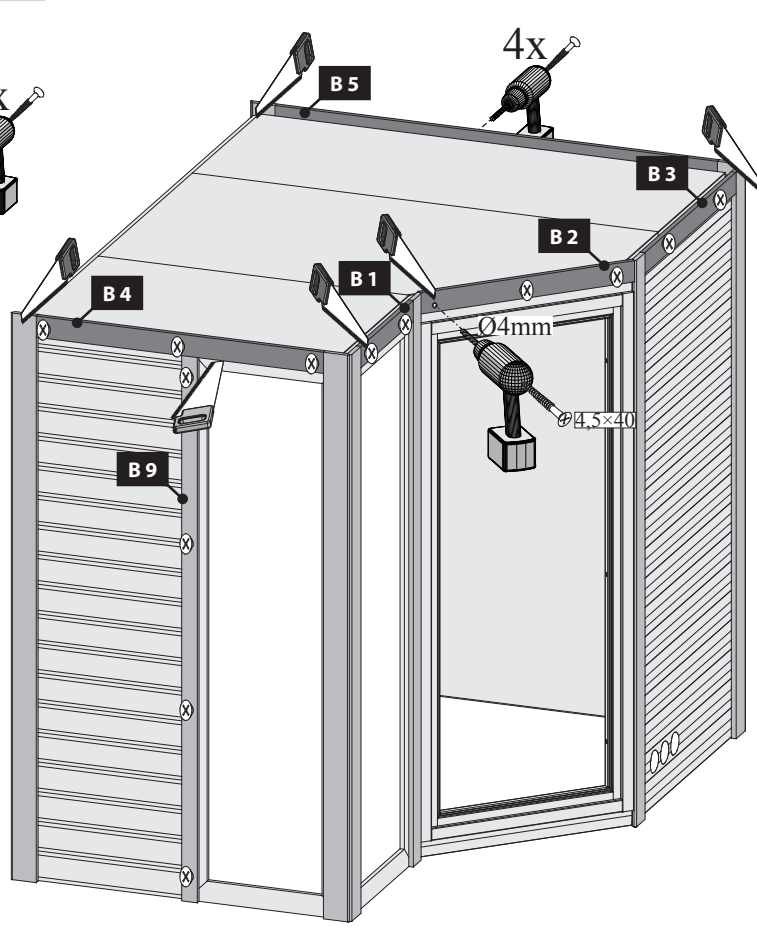

14

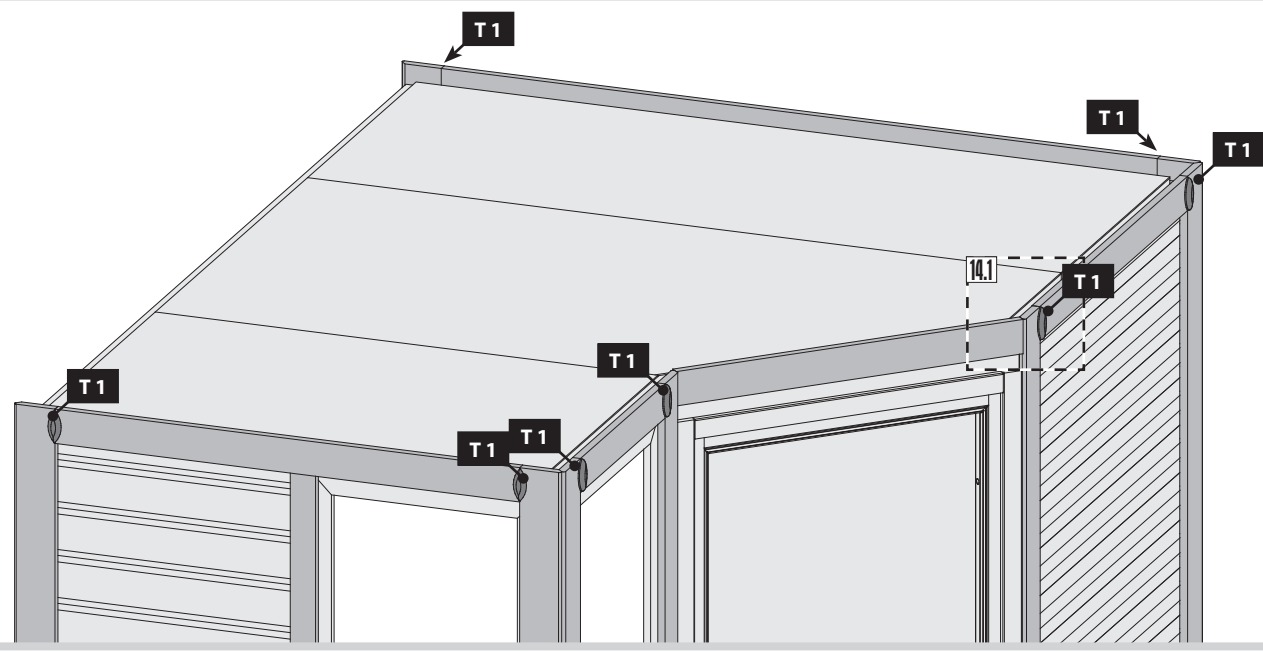

14.1

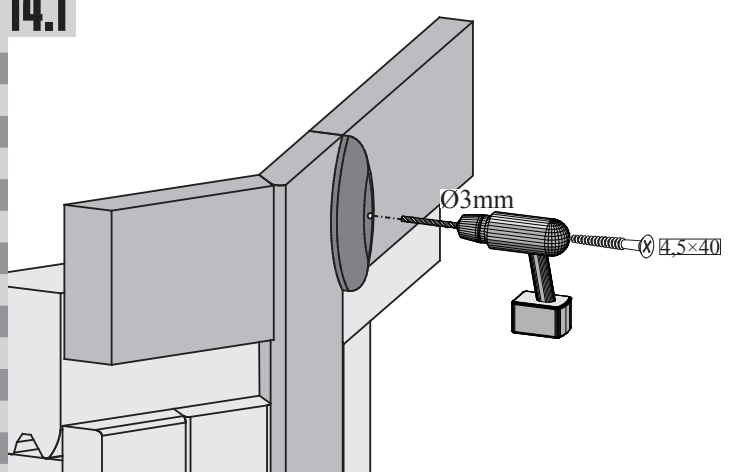

15





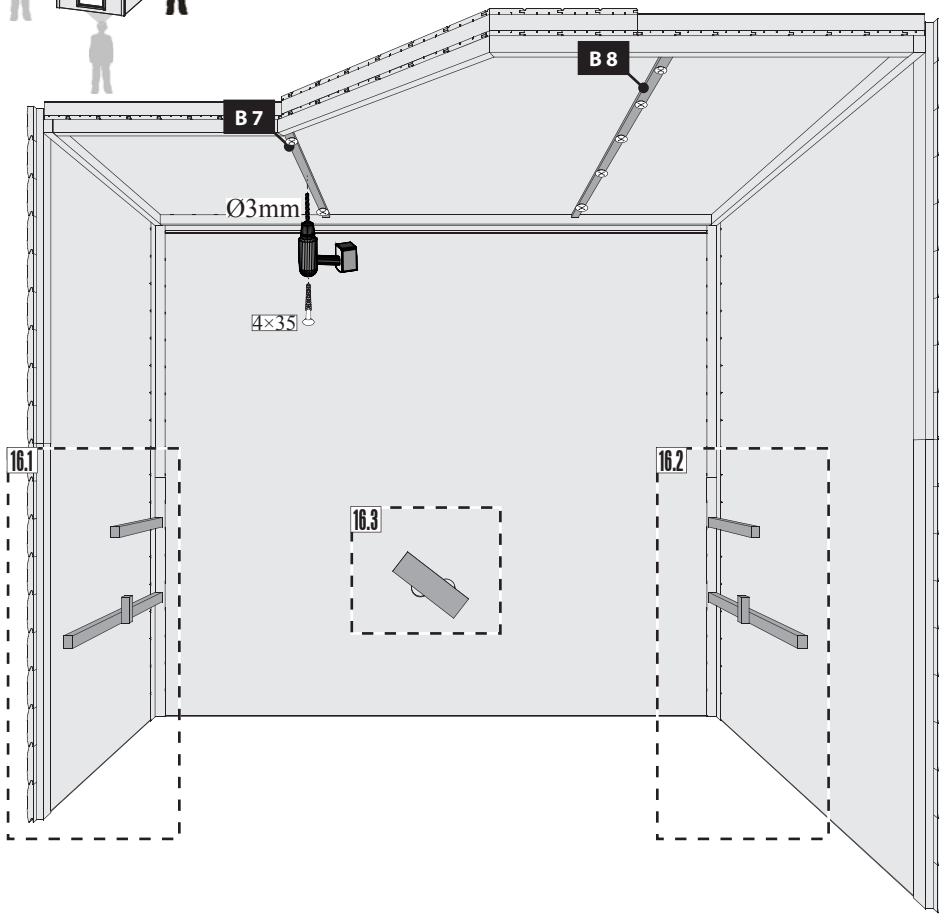
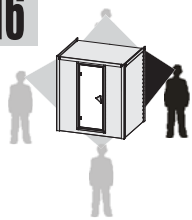

16



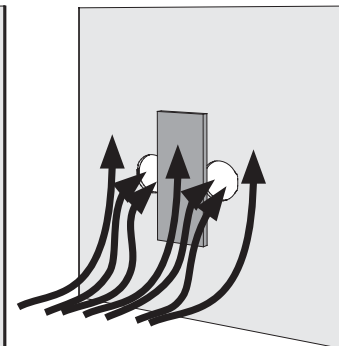
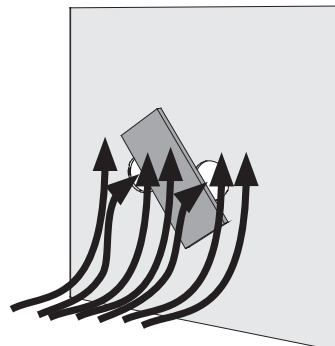
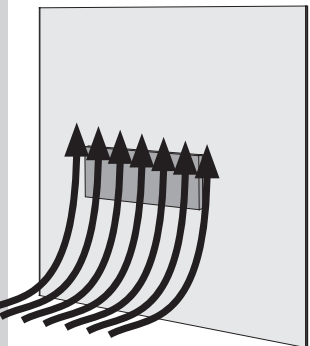
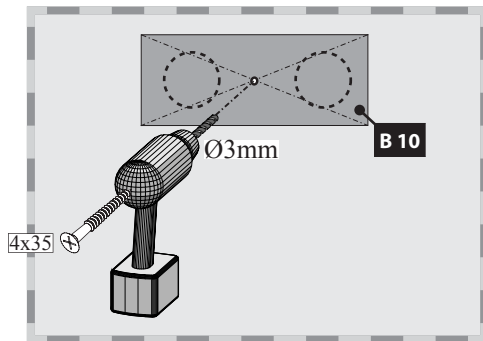

16.3





 Hier ist die Funktionsweise des Brettes abgebildet. Regeln Sie damit die Abluft nach Ihren eigenen Wünschen.

 Hier is de werking van het plankje afgebeeld. Regel daarmee de luchtafvoer naar eigen wens.

 Ceci représente le mode de fonctionnement de la planche. Avec elle, réglez l'écoulement de l'air selon vos désirs.

 Aquí está representada la forma de funcionamiento de la tabla. Regule con ello el aire de salida según sus propios deseos.

 This figure shows the functional principle of the board. Regulate the exhaust air according to your own wishes.

 Viene illustrato il principio di funzionamento della tavoletta di regolazione della ventilazione. Con essa si può regolare a piacere la ventilazione.

16.2-1

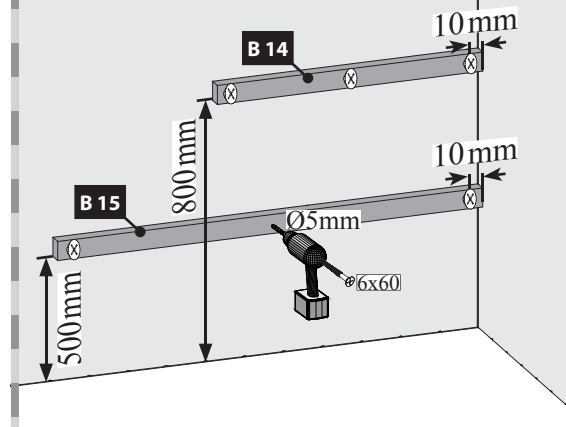

16.2-2

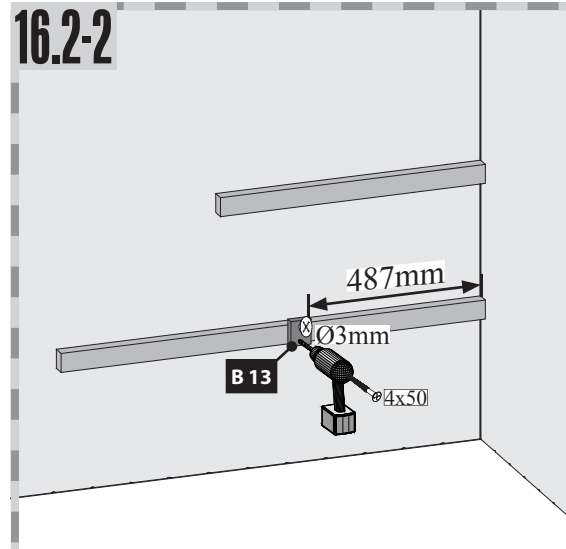

16.2-1

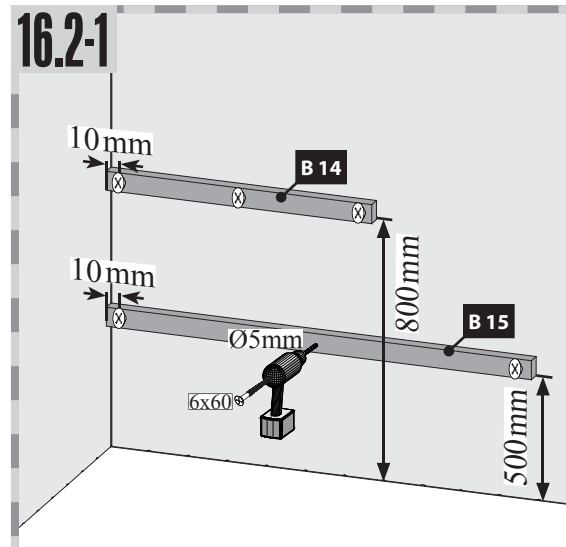

16.2-2

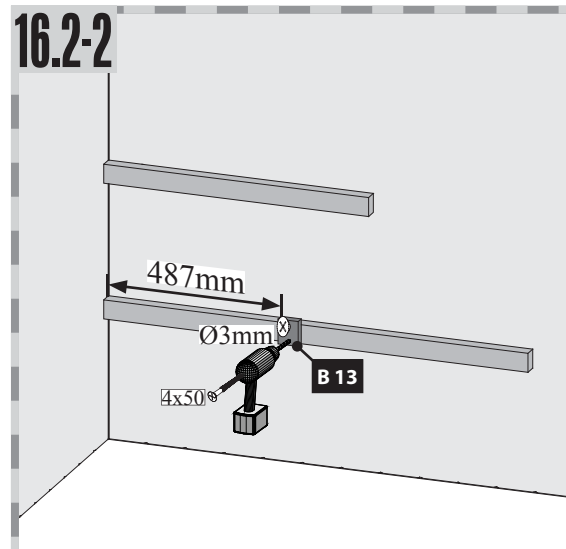

17

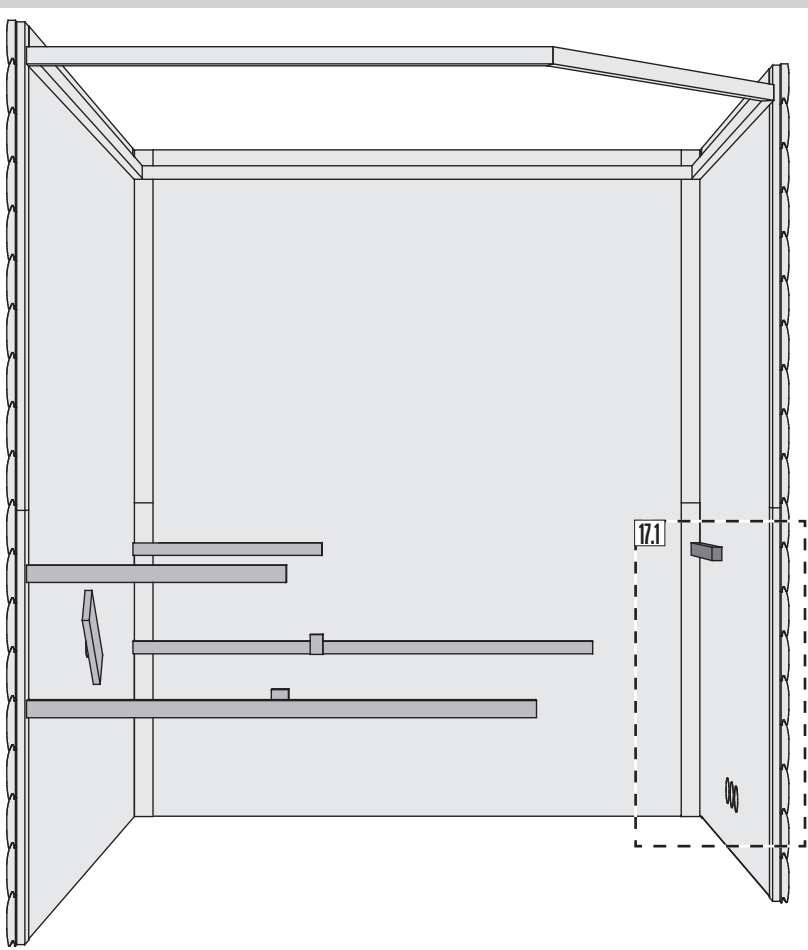

17.1-1

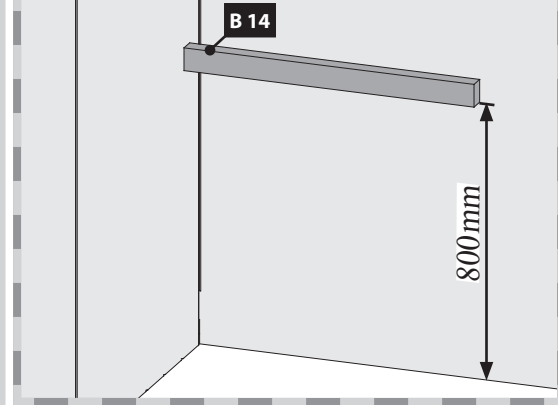

17.1-2

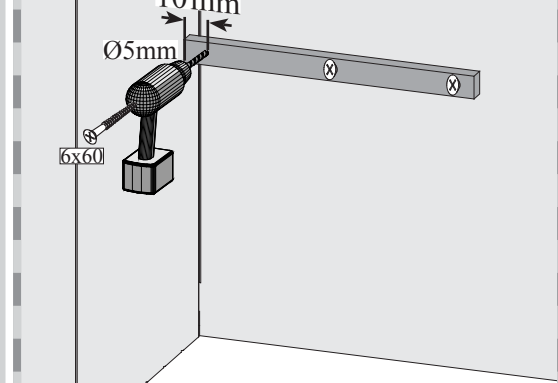

18

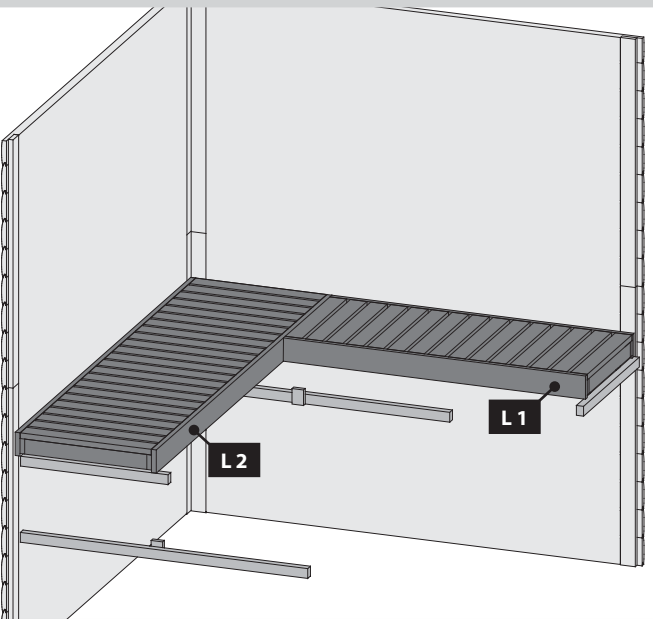

20

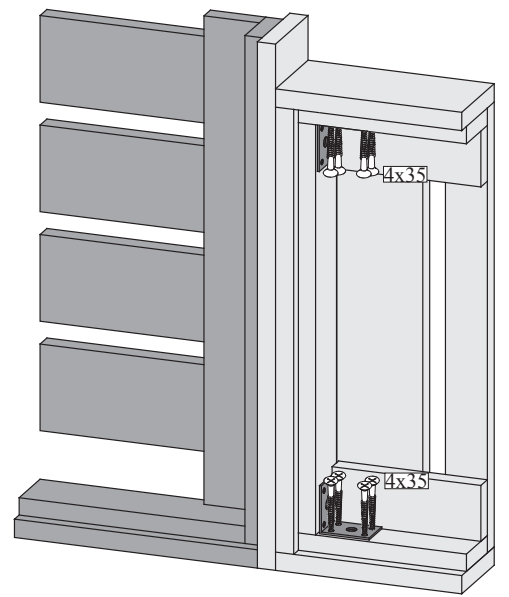

19

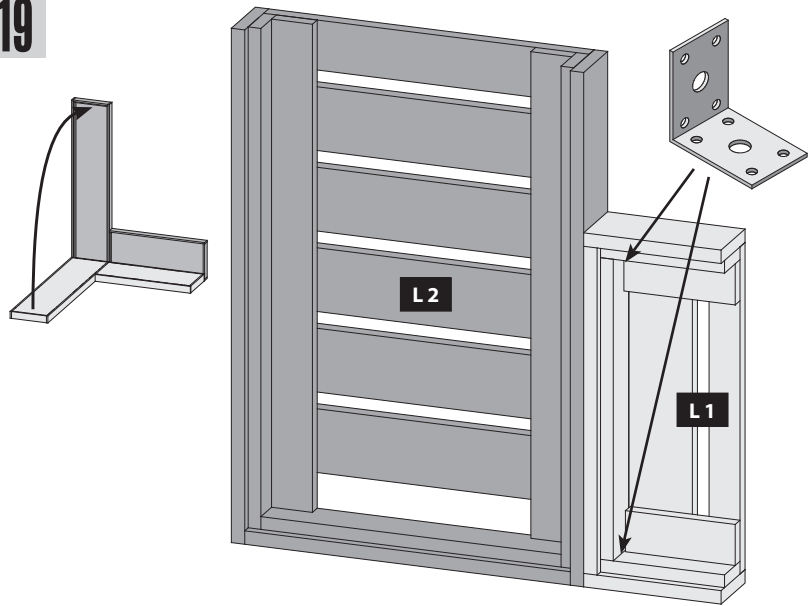

21

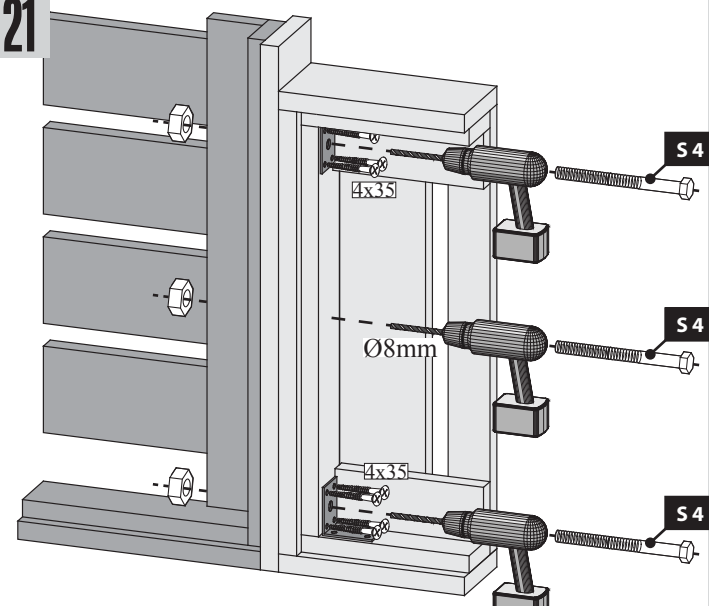

22

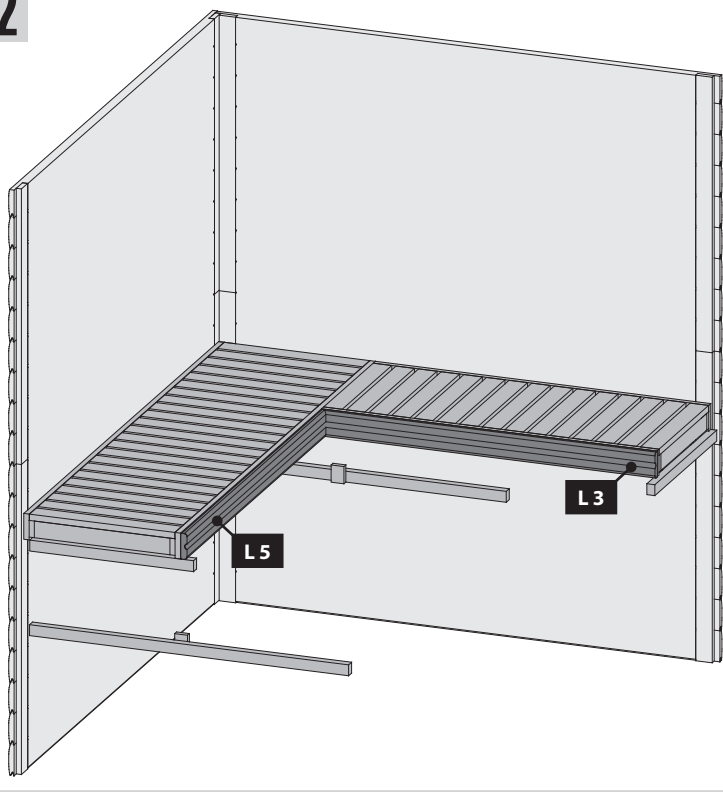

23



24

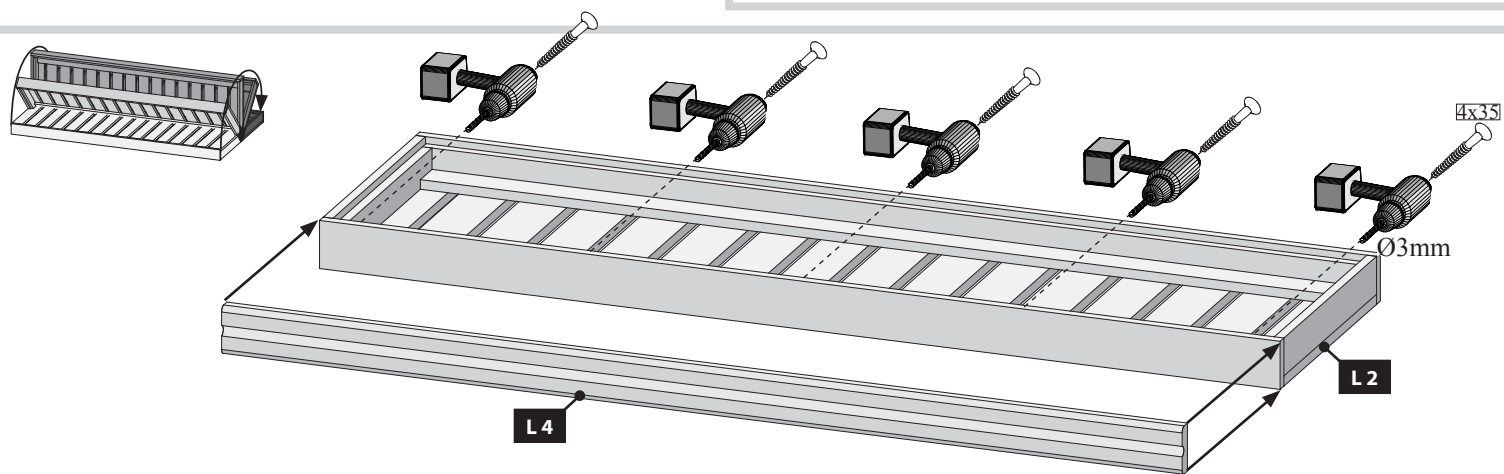

25

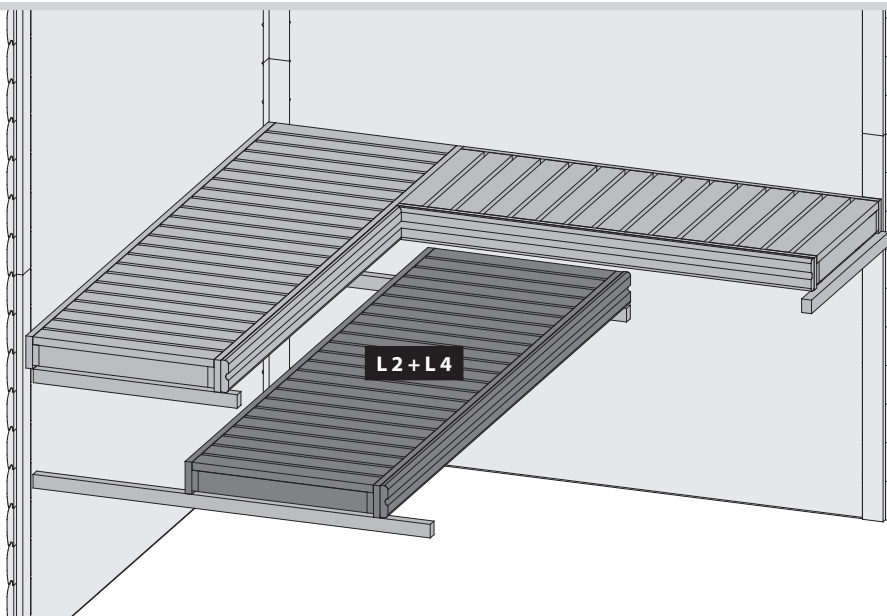

26 2x

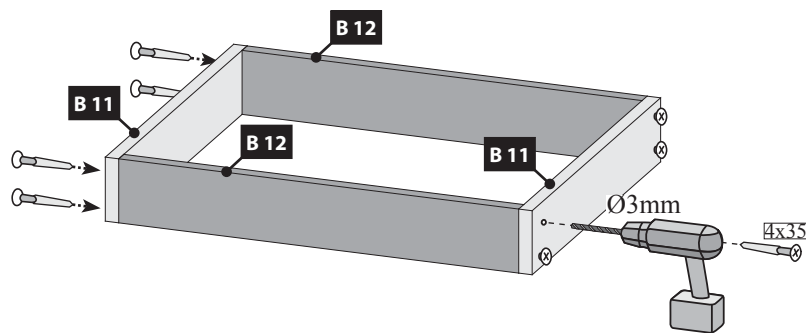

27 a

-  Nur bei 9 kW-Ofen
-  Seulement 9 kW chauffe
-  Only 9 kW heater
-  Slechts 9 kW heater
-  Sólo calentador de 9 kW
-  Solo riscaldamento 9 kW
-  Pouze topné těleso 9 kW

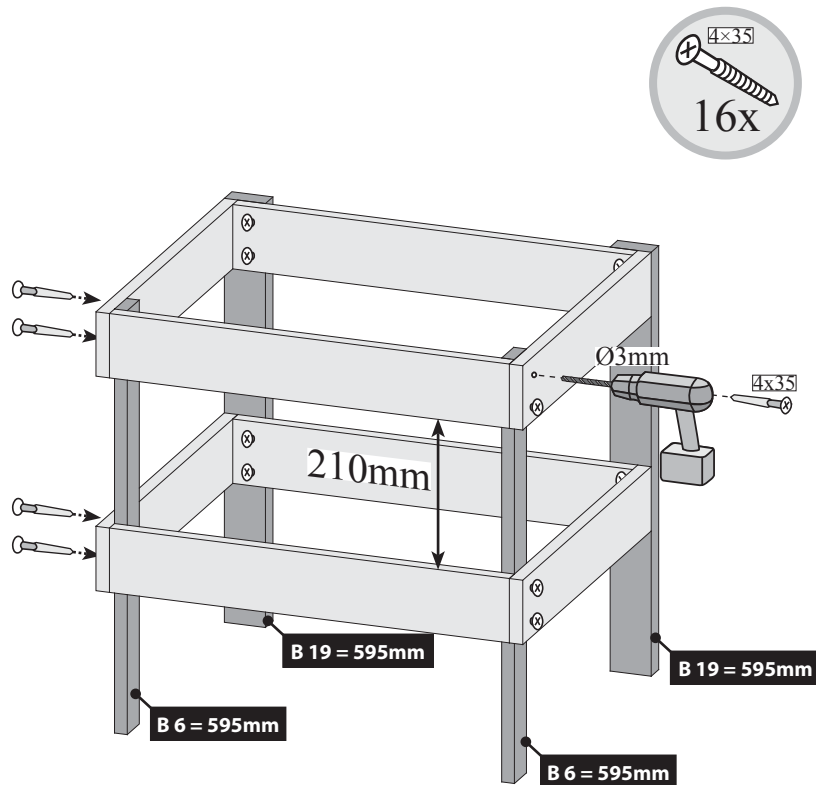
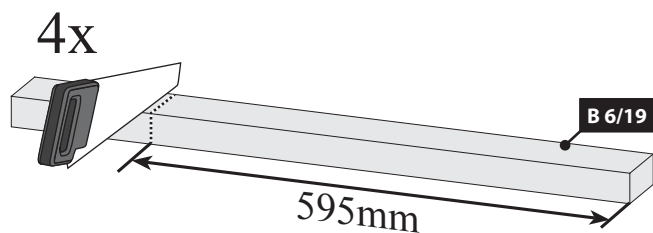

27 b

-  Bei allen anderen Öfen
-  Pour tous les autres fours
-  For all other furnaces
-  Voor alle andere ovens
-  Para todos los otros hornos
-  Per tutti gli altri tipi di forni
-  U všech ostatních pecích

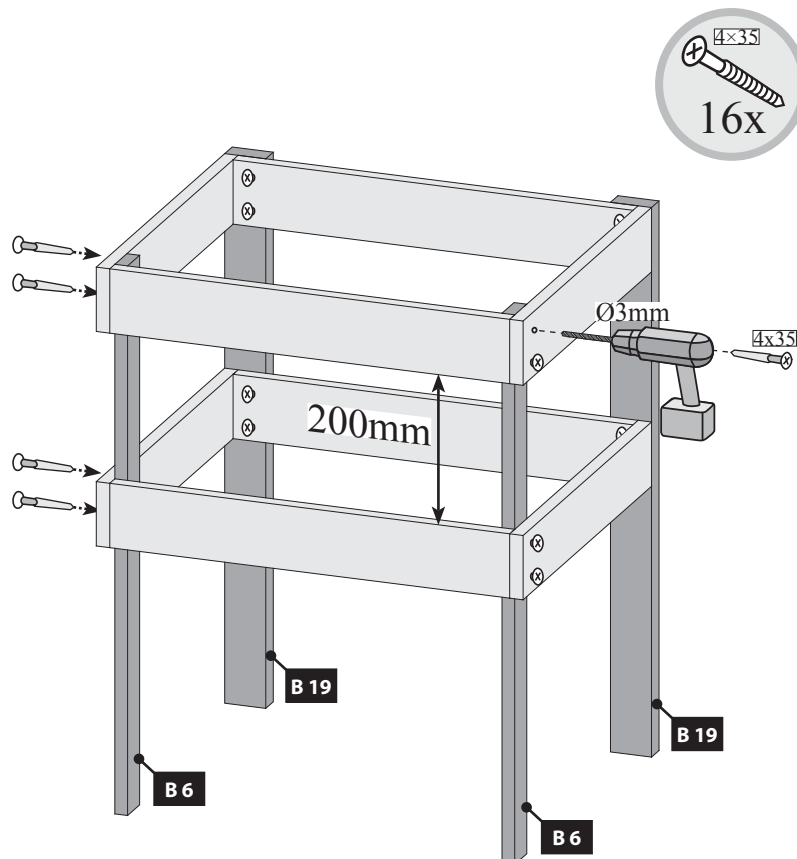

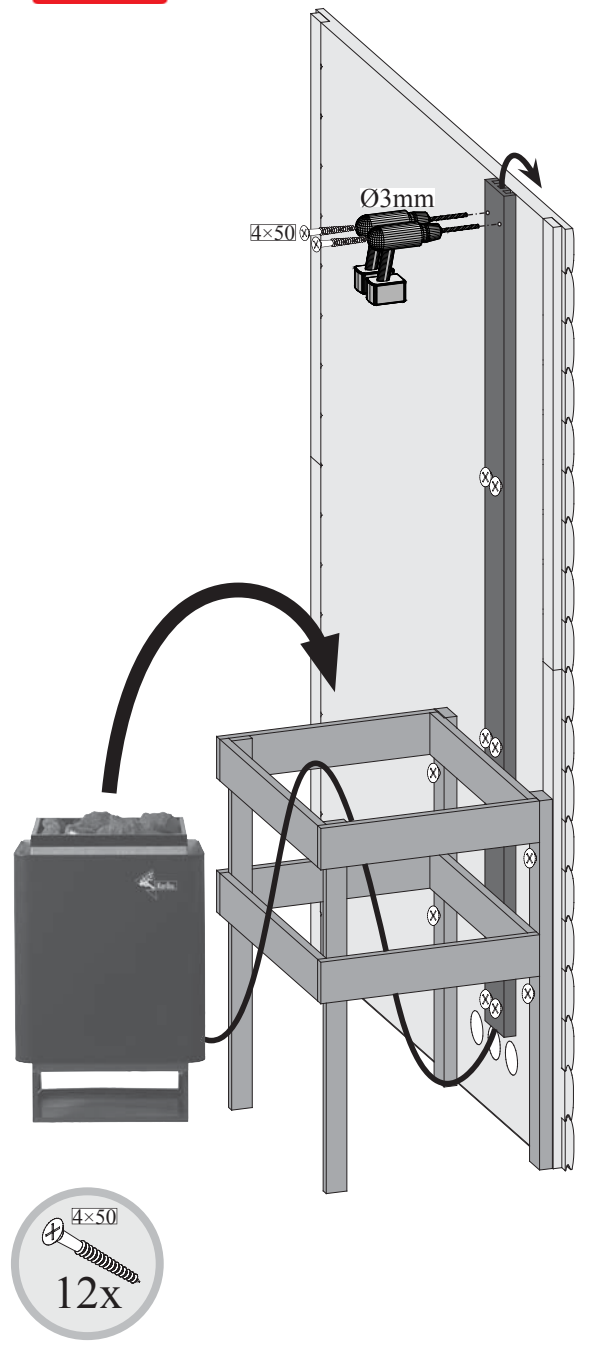
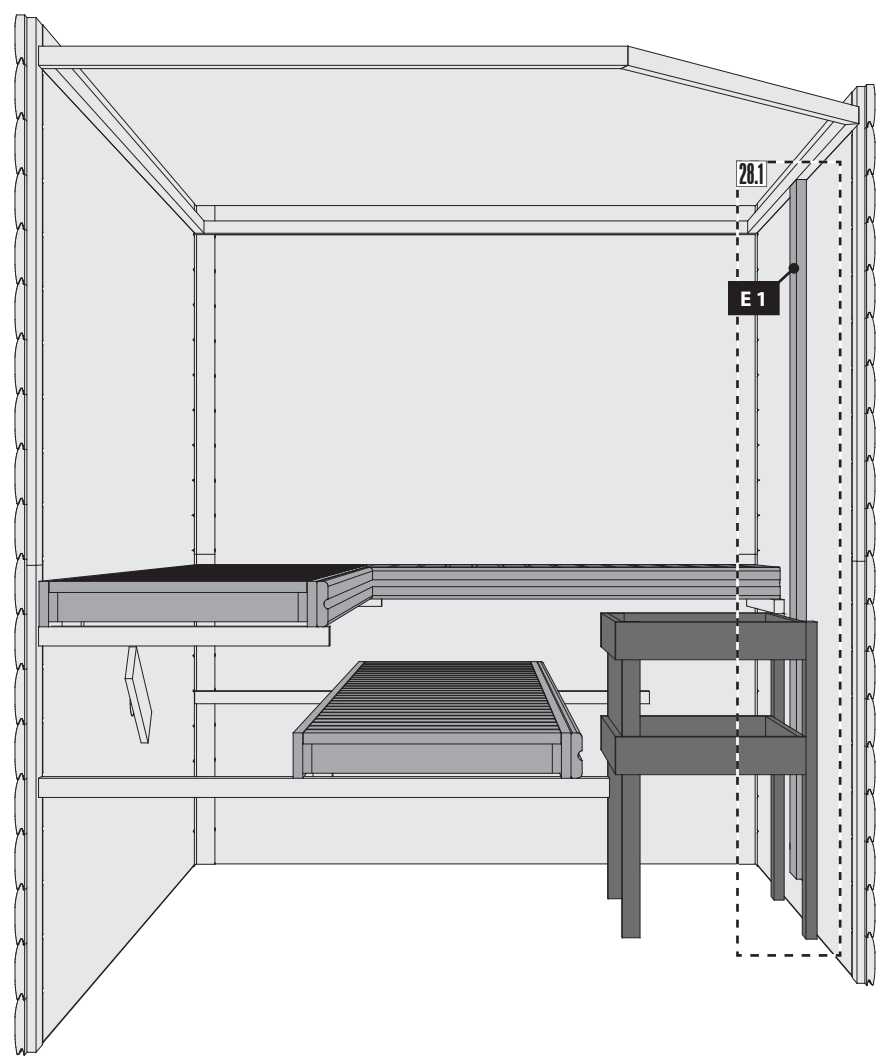

 Einbau Glastür

 Installation of glass door

 Montaje de la puerta de cristal

 Montage porte en verre

 Montage van de glazen deur

 Installazione portello di vetro

**!!!** 04 — 08 **!!!**

 Einbau Saunatür

 Installation de porte Sauna

 Sauna door installation

 Sauna deur installatie

 Instalación de la puerta Sauna

 Installazione porta Sauna

 Sauna Instalace dveře

01

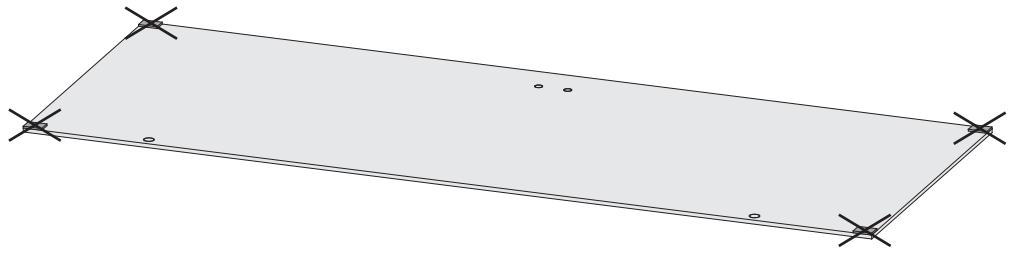

02

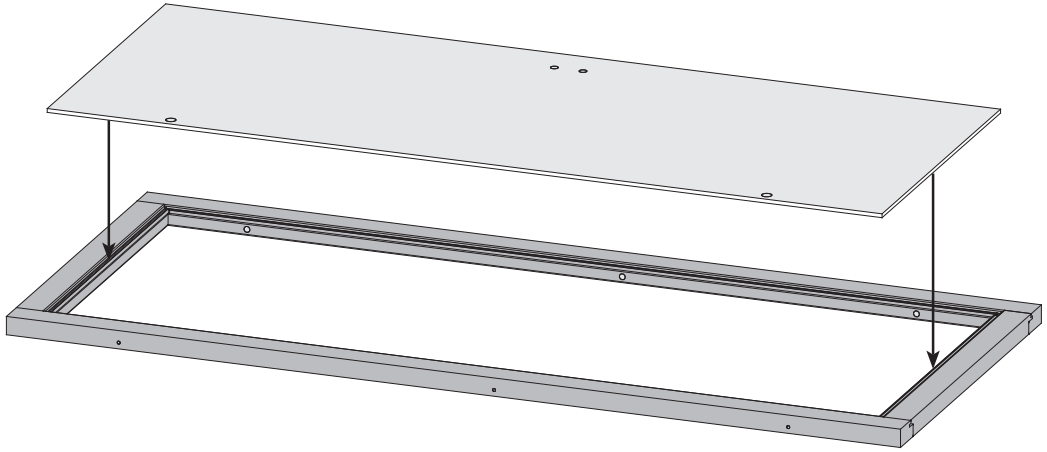

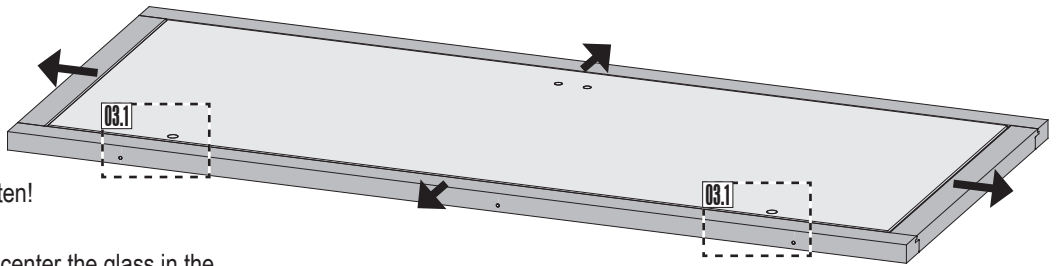

03



 Das Saunatürglas im Türrahmen ausrichten!

 Bien aligner le verre à vitre!

 To start building up the door you need to center the glass in the wooden frame!

 Plaats het glas van de sauna deur in het midden van het kozijn!

 ¡Centrar la puerta de cristal dentro del marco!

 Allineare il vetro dello sportello sauna al telaio della porta!

 Skleněná dvířka sauna v zárubně zarovnáni!

03.1-1

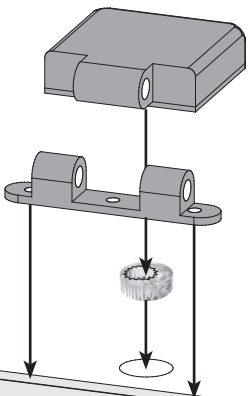

03.1-2

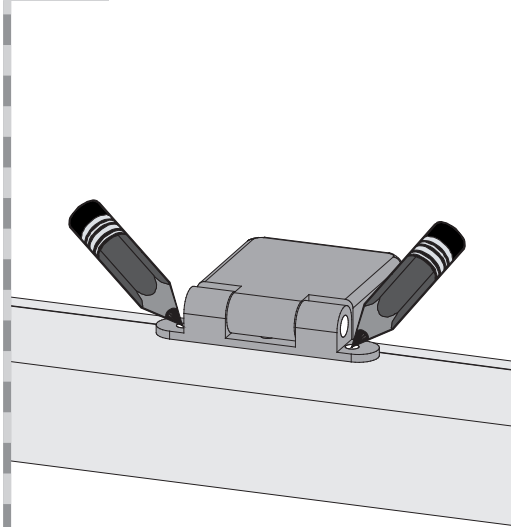

03.1-3

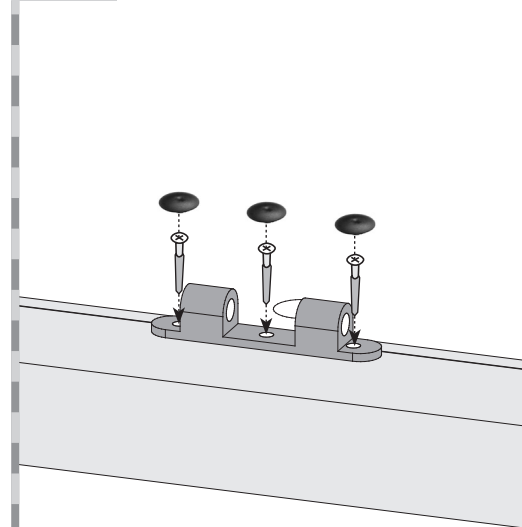

 Einbau Saunatür

 Sauna deur installatie

 Sauna Instalace dveře

 Installation de porte Sauna

 Instalación de la puerta Sauna

 Sauna door installation

 Installazione porta Sauna

04

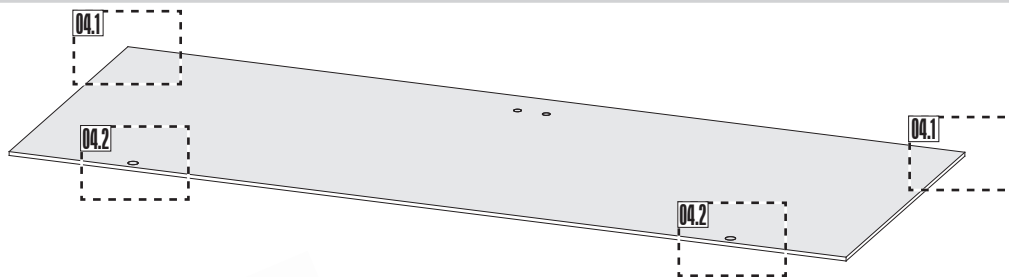

04.1-1

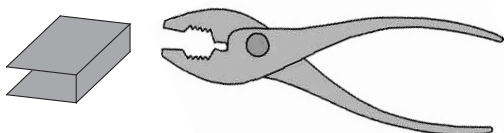

04.1-2

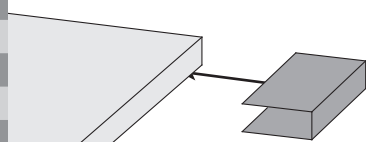

04.1-3

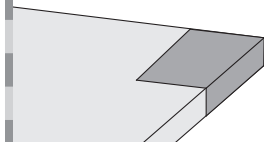

04.2-1

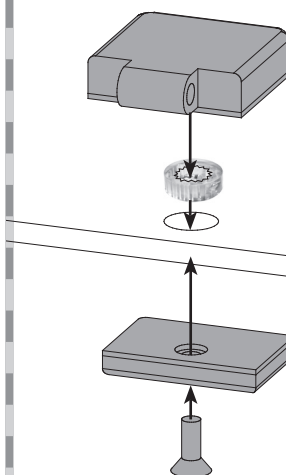

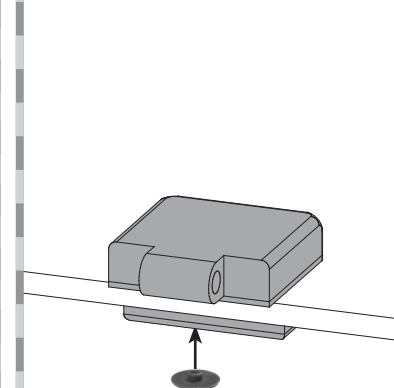

04.2-2



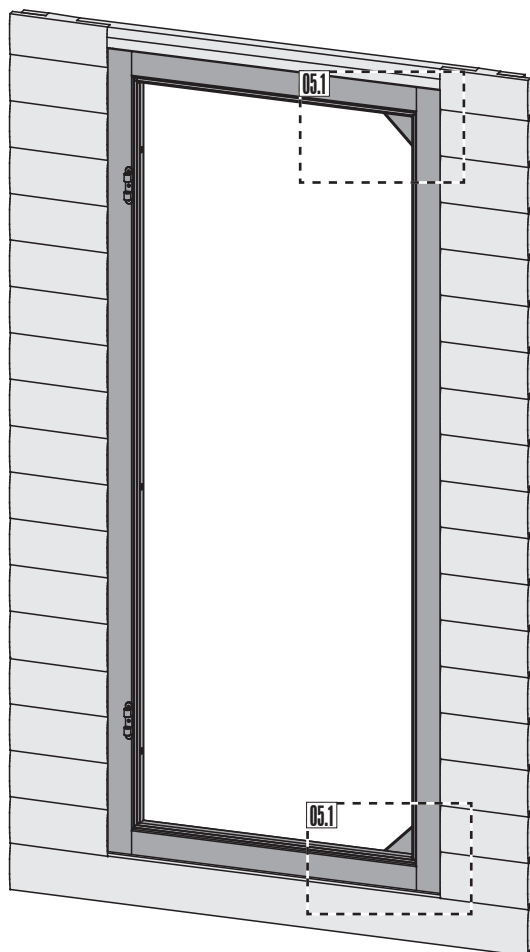

05





 Achtung: Alle Verstell-Excenter müssen in der Glasscheibe die gleiche Grundstellung haben!

 Attention: Tous les excentriques de positionnement doivent avoir la même position de base dans la vitre!

 Attention: All adjustable eccentrics must have the same basic adjustment in the glass panel!

 Attentie: alle excentrische verstelelementen moeten in dezelfde stand in de glasplaat worden geplaatst!

 Atención: Todos los excéntricos regulables tienen que tener la misma posición base en la hoja de cristal.

 Attenzione: Tutti gli eccentrici di regolazione devono avere la stessa posizione base nella lastra di vetro!

 Poznámka: Všechny nastavovací podivínů musí mít stejný základní polohy ve skle!

05.1-1



05.1-2



 Einbau Saunatür

 Sauna deur installatie

 Sauna Instalace dveře

 Installation de porte Sauna

 Instalación de la puerta Sauna

 Sauna door installation

 Installazione porta Sauna

06

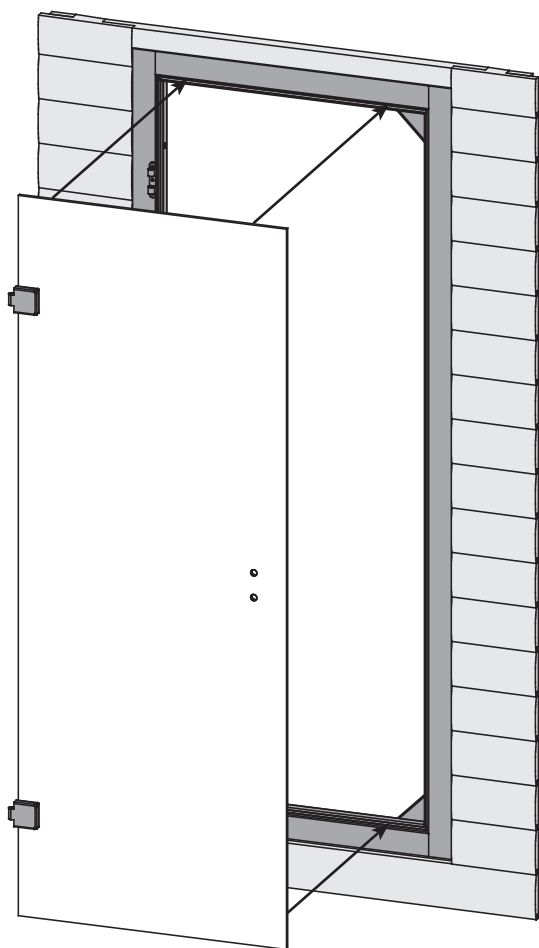

07

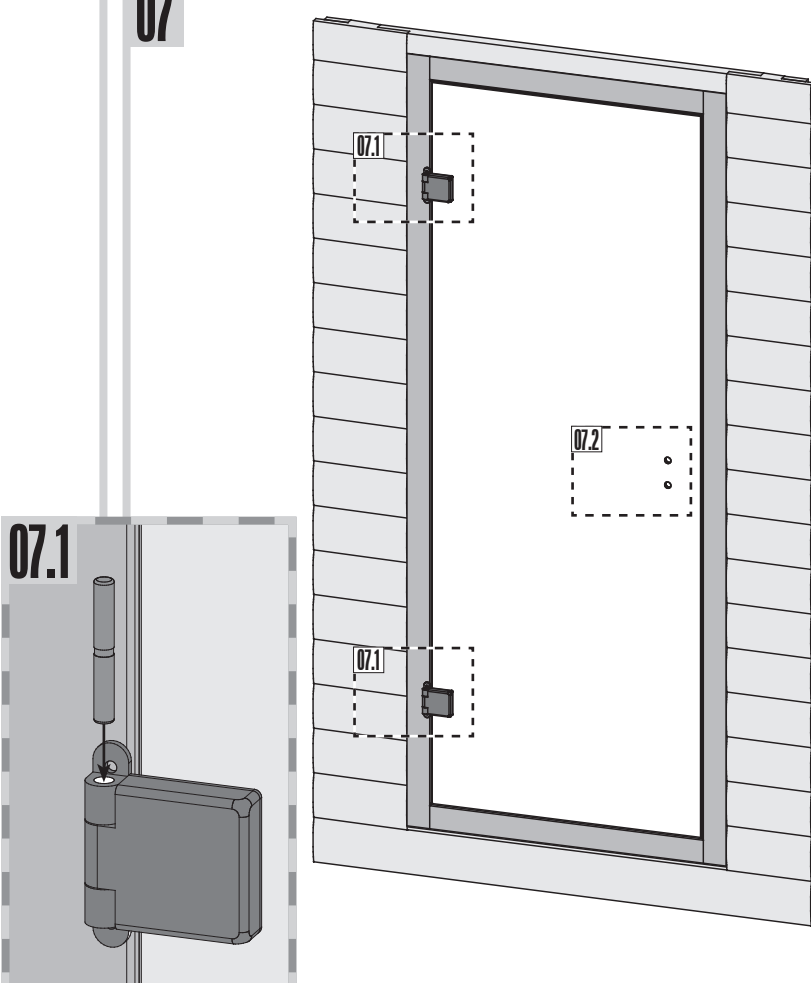

07.2-1

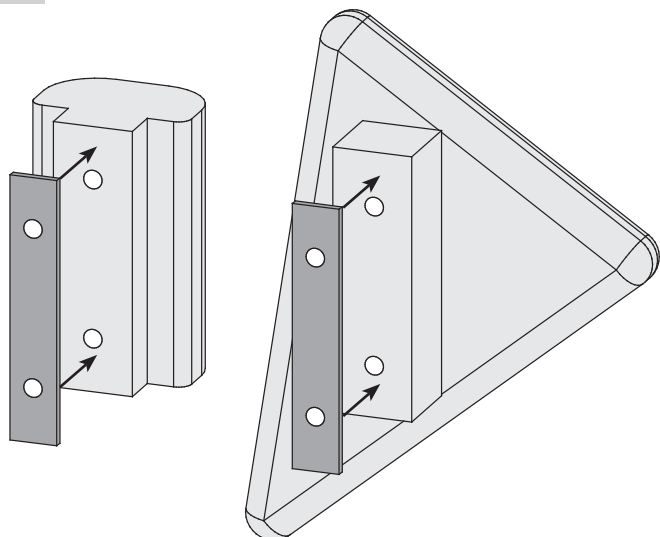

07.2-2

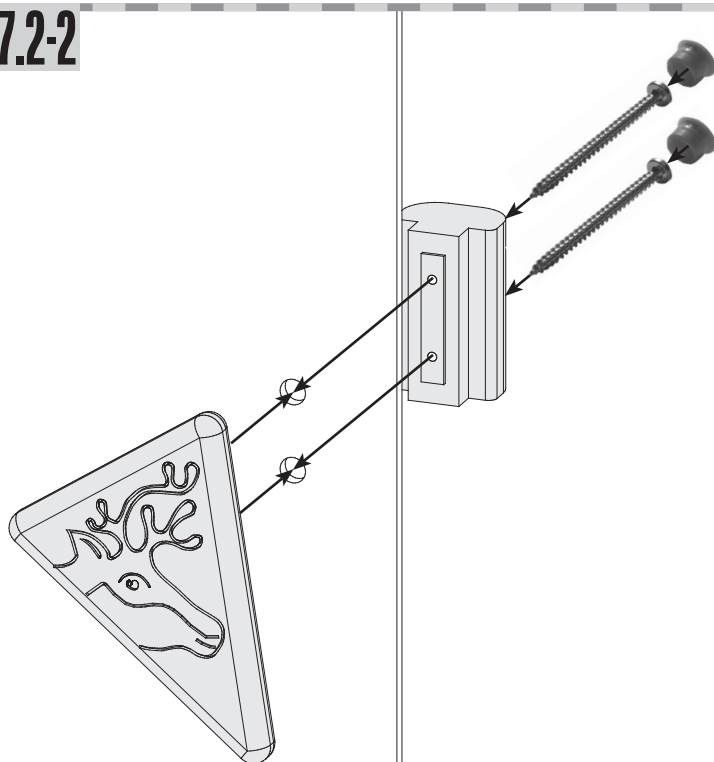



 Einbau Saunatür

 Sauna deur installatie

 Sauna Instalace dveře

 Installation de porte Sauna

 Instalación de la puerta Sauna

 Sauna door installation

 Installazione porta Sauna

08

 **Seitenverstellung + Höhenverstellung**

Achtung: Alle Verstell-Excenter müssen in der Glasscheibe die gleiche Grundstellung haben!

 **Positionnement latéral + positionnement hauteur**

Attention: Tous les excentres de positionnement doivent avoir la même position de base dans la vitre!

 **Lateral adjustment + height adjustment**

Attention: All adjustable eccentrics must have the same basic adjustment in the glass panel!

 **Zijverstelling + hoogteverstelling**

Attentie: alle excentrische verstelelementen moeten in dezelfde stand in de glasplaat worden geplaatst!

 **Regulación lateral + regulación de la altura**

Atención: Todos los excéntricos regulables tienen que tener la misma posición base en la hoja de cristal.

 **Regolazione laterale + regolazione dell'altezza**

Attenzione: Tutti gli eccentrici di regolazione devono avere la stessa posizione base nella lastra di vetro!

 **Boční nastavení + nastavení výšky**

Poznámka: Všechny nastavovací podivínů musí mít stejný základní polohy ve skle!

